

UltimateHome 700 Robotic Vacuum + Mop with Clean Station



Product Details

FEATURES

Long runtime

Intuitive Navigation

2-in-1 Vacuum and Mop

Powerful Suction

BENEFITS

UP TO 140 MINUTES* OF RUNTIME

Let the robot cleaner take care of your floor cleaning without interruption for up to 140 minutes* of runtime, for coverage of up to 140m of floor space.*Based on internal tests on quiet mode without mop settings and empty water tank.

PRECISION WITHOUT SUPERVISION

Precise LiDAR technology accurately maps your home floor layout to track the most efficient, obstacle-free path for complete, effective home cleaning.

MOPS WHILE IT VACUUMS

Let the robot cleaner simultaneously vacuum and mop your hard floors, and enjoy the efficiency of thorough 2-in-1 robotic cleaning.

POWERFUL SUCTION ON ALL FLOORS

With up to 4000Pa* suction, this robot cleaner delivers high-performance vacuuming, effortlessly. Powerful pick-up, from fine dust to large particles**, ensures an effective clean on all floor types. *Internal test on max mode. **Internal test according to IEC 60312-1 on fine, medium and large particle sizes on both carpets and hard floors.

Specifications

MAIN

Brand	Electrolux
-------	------------

Product Type	Robot
--------------	-------

PNC	900402287
-----	-----------

EAN/UPC	7333394029252
---------	---------------

Model/Part number	EFR71222DS
-------------------	------------

Replaces model	-
----------------	---

Description	700 Electrolux
-------------	----------------

Vacuum Bag/Bagless	Bagless
--------------------	---------

Clean Station Bag/Bagless	Bagged
---------------------------	--------

Warranty Period	2 years
-----------------	---------

TECHNICAL SPECIFICATIONS

Volt (V)	14.8
----------	------

Battery cell, type	Li-ION
--------------------	--------

DESIGN

Main colour	Shell White
-------------	-------------

Base colour	White
-------------	-------

ACCESSORIES / NOZZLE

Accessories	Yes
-------------	-----

Small brush	N/A
-------------	-----

ACCESSORIES / NOZZLE

Crevice tool	N/A
--------------	-----

Upholstery tool	N/A
-----------------	-----

PACKAGING & LOGISTICS

SINGLE PACKAGE

Gross weight (kg)	9.3
-------------------	-----

Package width (mm)	395
--------------------	-----

Package depth (mm)	385
--------------------	-----

Package height (mm)	475
---------------------	-----

Palette, units per	18
--------------------	----

Palette, layers per	3
---------------------	---

Max units in 20 ft cont.	375
--------------------------	-----

Max units in 40 ft cont.	750
--------------------------	-----

Dimensions

Model:
EFR71222DS

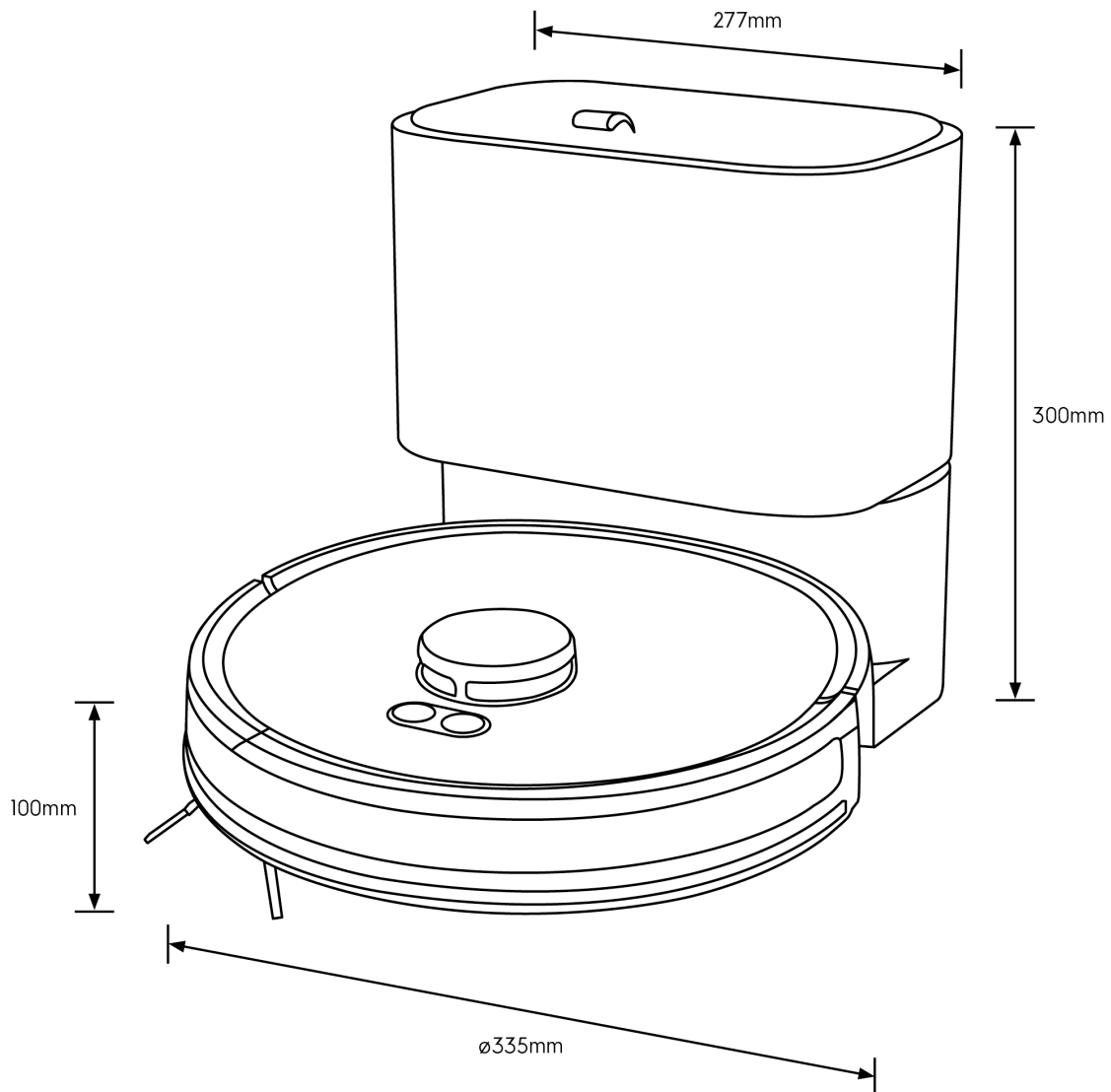

© 2023 Electrolux S.E.A PTE. LTD. ELX_DIM_EFR71222DS_Oct23

Terms and Conditions

IMPORTANT

This is a guide of product dimensions only. For complete installation instructions, refer to the manual provided with product.

PRODUCT INFORMATION

The descriptors and illustrations in this publication apply to the specific products and models described as at the date of issue. Under our policy of continuous product development, product specifications may change without notice. Prospective purchasers should therefore check with their retailer to ensure this publication correctly describes the products that are being offered for sale. All information supplied is to be used for general reference purposes only and is on the understanding that Electrolux Home Products Pty Ltd (Australia) and Electrolux (NZ) Ltd (New Zealand) will not be liable for any loss, liability or damage of whatever kind arising as a result of reliance on such information. Colours of products illustrated are as close as printing limitations allow. Electrolux will at all times comply with its obligations pursuant to law including Trade Practices (Australian Consumer Law) Act and Regulations.

WARRANTY

This appliance is warranted against manufacturing defects in Australia and New Zealand for 24 months following the date of original purchase of the Appliance, where the Appliance is used for personal, domestic or household use (i.e. normal single family use) as set out in the instruction manual. Where the Appliance and accessories (including nozzles, brushes or other cleaning attachments) are used for commercial purposes, the Appliance will then be warranted against manufacturing defects in Australia for 3 months and in New Zealand for 3 months, following the date of original purchase of the Appliance.

ELECTROLUX FLOOR CARE & SMALL APPLIANCES AUSTRALIA

telephone: 1300 366 366

fax: 1800 673 326

email: info@electrolux.com.au

web: www.electrolux.com.au

ELECTROLUX FLOOR CARE & SMALL APPLIANCES NEW ZEALAND

telephone: 05 08 730 730

fax: 09 573 2382

email: floor.care@electrolux.co.nz

web: www.electrolux.co.nz