

**52cm stainless steel integrated rangehood with maximum airflow of 650m<sup>3</sup>/hr, push button electronic control and 3 speed twin fan motor plus boost.**



## Product Details

### FEATURES

---

Max airflow of 650m<sup>3</sup>/h

Operation noise as low as  
52dB(A)

Multi-layer filters

Dishwasher safe filters

---

LED lighting

3 speed fan + Boost Function

Electronic pushbutton  
controls

---

### BENEFITS

---

Maximise your airflow

Remove odours and vapours quickly and efficiently with a high  
airflow rate of 650m<sup>3</sup>/h

Keep the noise down

With noise levels as low as 52dB(A), keep the conversation  
going smoothly when entertaining guests.

---

Clear visibility for complete control

Long lasting LED lights illuminates the complete cooking  
surface giving you full control over your delicious cuisine.

---

## Specifications

### PRODUCT PROFILE

---

Domestic warranty details (yrs) 2

---

Type of Rangehood integrated under cupboard

---

Nominal width (cm) 600

---

Finish of Rangehood stainless steel

---

### DIMENSIONS

---

Total product height (mm) 305

---

Total product width (mm) 522

---

Total product depth (mm) 284

---

### MOTOR/FAN

---

Number of fans 2

---

Number of fans speeds 4

---

Variable speed control Yes

---

Type of motor centrifugal

---

Perimeter extraction No

---

Auto fan timer No

---

Maximum airflow M3/Hr 650

---

Noise level dB high 70

---

Noise level dB low 52

---

### CONTROLS

---

Control panel electronic push button

---

LED speed display No

---

Removal front fascia No

---

## DIMENSIONS

---

Diameter of ducting (mm) 150

---

Minimum installation height  
from cooking surface Gas  
(mm) 650

---

Minimum installation height  
from cooking surface  
Electric (mm) 600

---

## FILTERS

---

Number of filters 2

---

Type of filter multilayer aluminum  
micromesh filters

---

Dishwasher safe Yes

---

## DUCTING / RECIRCULATION

---

Ducting yes

---

Top or rear duct hole top

---

Recirculation option Yes

---

Front recirculating option No

---

Optional extension flue No

---

## LIGHTS

---

Number of lights 2

---

Wattage of light 4

---

Type of light LED

---

## SHIPPING

---

Shipping Weight (Kg) 6.3

---

Product Weight (Kg) 4

---

Pack Dimensions Height  
(mm) 425

---

Pack Dimension Width  
(mm) 605

---

**DUCTING / RECIRCULATION**

---

Ducting diameter (mm)	150
-----------------------	-----

---

**SHIPPING**

---

Pack Dimension Depth (mm)	363
---------------------------	-----

---

## Dimensions

### Dimensions

	width	height	depth
Duct diameter	150		
Product (mm)	522	305	284

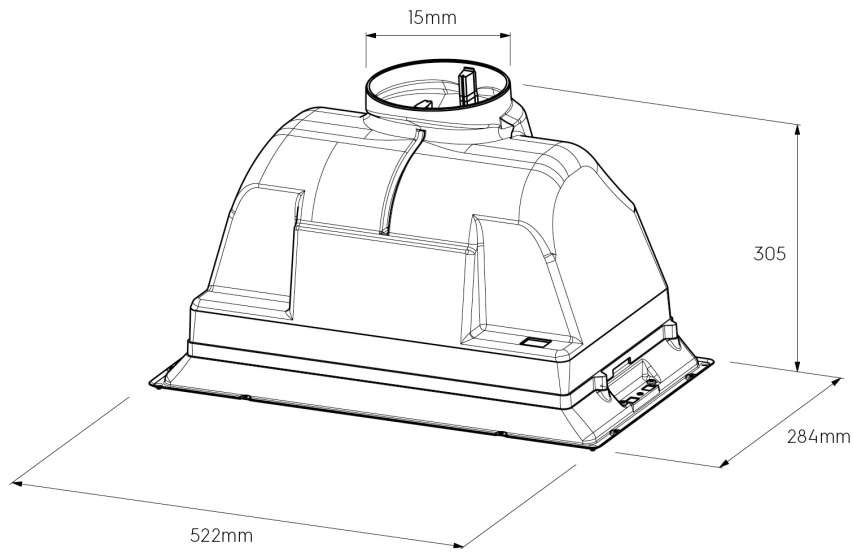

## Terms and Conditions

### IMPORTANT

This is a guide of product dimensions only. For complete installation instructions, refer to the manual provided with product.

### PRODUCT INFORMATION

The descriptors and illustrations in this publication apply to the specific products and models described as at the date of issue. Under our policy of continuous product development, product specifications may change without notice. Prospective purchasers should therefore check with their retailer to ensure this publication correctly describes the products that are being offered for sale. All information supplied is to be used for general reference purposes only and is on the understanding that Electrolux Home Products Pty Ltd (Australia) and Electrolux (NZ) Ltd (New Zealand) will not be liable for any loss, liability or damage of whatever kind arising as a result of reliance on such information. Colours of products illustrated are as close as printing limitations allow. Electrolux will at all times comply with its obligations pursuant to law including Trade Practices (Australian Consumer Law) Act and Regulations.

### WARRANTY

This warranty only applies to Appliances purchased and used in Australia or New Zealand and used in normal domestic applications and is in addition to (and does not exclude, restrict, or modify in any way) any non-excludable statutory warranties in Australia or New Zealand. All warranties are subject to the conditions set out in the warranty card accompanying the product when purchased.

#### ELECTROLUX HOME PRODUCTS AUSTRALIA

telephone: 1300 363 640

fax: 1800 350 067

email: [customercare@electrolux.com.au](mailto:customercare@electrolux.com.au)

web: [www.electrolux.com.au](http://www.electrolux.com.au)

#### ELECTROLUX HOME PRODUCTS NEW ZEALAND

telephone: 09 573 2230

fax: 09 573 2221

email: [customercare@electrolux.co.nz](mailto:customercare@electrolux.co.nz)

web: [www.electrolux.co.nz](http://www.electrolux.co.nz)