

INSTRUCTION BOOK

GB

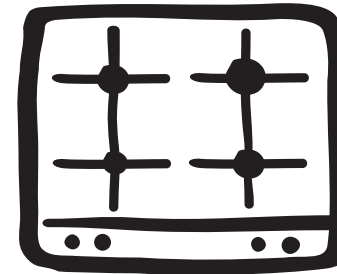

B1760

Model No.	EHT632 X
Product No	949 600 562
Serial No.	

3 25 88-7560 Rev. 3-236

AUS

NZL

Table of contents

Contents	Page no
For the user	
Safety information	3
Description of the product	5
Operations	6
Burner ring	7
Burner cover	7
Ignition electrode (A)	7
Thermo Sensor (B)	7
Ignition	8
Cleaning and maintenance	9
Stainless steel surfaces	9
Cleaning of gas burners	10
Avoid boil over	10
Service	17
Electrolux warranty Australien	18
Electrolux appliance warranty - New Zealand	20
For the installer	
Mounting	11
Technical data	16

How to read the operating instructions:

1... 2...Step by step

 Hint and tips

 Safety information

 Environmental information



Safety information

These warnings are provided in the interests of your safety. Ensure you fully understand them before installing or using the appliance. Your safety is of paramount importance. If you are unsure about the meaning of these warnings contact the Customer Care Department for assistance.

Installing

This appliance must be installed according to the instructions supplied. Any installation work must be undertaken by an authorised competent person. Do not alter the specifications or attempt to modify the appliance in any way.

During Use

The appliance is intended for domestic cooking only. It is not designed for commercial/industrial purposes.

Ensure that the control knob is in the OFF position when not in use.

Do not use the appliance if it is damaged in any way, contact your local Electrolux Service Centre.

Never use plastic or aluminium dishes on the appliance.

Never leave the appliance unattended while deep frying, or heating fats and oils.

Ensure pots are placed centrally over the burner and do not overhang the bench surface or control knobs.

Do not allow pots to boil dry.

Do not use or store flammable materials near this appliance. Do not spray aerosols in the vicinity of this appliance while it is in operation. Where this appliance is installed in marine craft or caravans, it shall not be used as a space heater

The appliance is not intended for use by young children or infirm persons without supervision.

Child Safety

Young children should be supervised to ensure that they do not play with the appliance

The appliance gets hot when it is in use. Children should be kept away until the appliance has cooled.

Maintenance and Cleaning

Only clean this appliance in accordance with the instructions given in this book.

Service

Repairs carried out by inexperienced persons may cause injury or serious malfunction of the appliance. Repairs must only be carried out by an authorised person. Contact your local Electrolux Service Centre;

For service within Australia:
Please phone 131349 (Australia only).

For service within New Zealand:
Please phone 0800 106 610 (Free Call New Zealand Only).

Disposal

Make the gas hob unusable by cutting off the cable
Dispose of any packaging material and old appliances at an authorised disposal sites.

The primary air intake aperture

Must never be accidentally blocked by objects of any kind.

- 11 The Company (and any company related to the Company) will not be liable for any special incidental or consequential damages or for loss, damage or expense directly or indirectly arising from the use or inability to use this appliance, or for personal injury or loss or destruction of other property.
- 12 Nothing in this warranty is intended to limit the rights you may have under the Consumer Guarantees Act 1993, except to the extent permitted by that Act, and all provisions of this warranty shall be read as modified to the extent necessary to give effect to that intention.
- 13 The Consumer Guarantees Act 1993 does not apply if your appliance is acquired for the purposes of a “business” (as defined in that Act).
- 14 This warranty is limited to 90 days from date of purchase if the appliance is used for commercial use.

IMPORTANT NOTICE

Before calling a service technician please carefully check the warranty terms and conditions, the operating instructions and service booklet if applicable. If the product fails for any of the customer responsibility

reasons detailed therein, a service fee will be charged. Please present proof of purchase to any Authorised Service Centre should warranty service be required.

SERVICE CENTRES

PLEASE PHONE 0800 10 66 10

For your nearest Authorised Service Centre please look in The Yellow Pages under Home Appliance Servicing or Call 0800 10 66 10

ELECTROLUX APPLIANCE WARRANTY – NEW ZEALAND

This appliance is warranted by Electrolux Home Products (NZ) Ltd (“the Company”) from the date of purchase. The following terms and conditions apply:

- 1 The Company or its Authorised Service Centre will pay the cost of repairing or replacing all parts of the appliance which the Company or its Authorised Service Centre find defective for a period of 24 months following the date of purchase (the “Warranty Period”).
- 2 During the Warranty Period the Company or its Authorised Service Centre, will pay the cost of repairing or replacing all parts, which they find are defective.
- 3 Light globes, batteries and filters are replaceable parts and are not covered under this warranty.
- 4 The appliance must be installed and operated in accordance with the Company’s instructions.
- 5 This Warranty does not apply to normal wear and tear, or any service, which is needed after an accident, negligence, alteration or misuse.
- 6 This Warranty also does not apply to damage caused if your appliance has been dismantled, repaired or serviced by any

person other than someone authorised by the Company.

- 7 If you live outside the service area of the Company or its Authorised Service Centre, this warranty does not cover the cost of transport of the appliance for service nor the Authorised Service Centre’s travelling costs to and from your home.
- 8 If you are required to transport the appliance to the Company or its Authorised Service Centre, it must be securely packed and insured.
The Company does not accept any responsibility for loss or damage prior to it being received by the Company or its Authorised Service Centre.
- 9 This warranty is the only express warranty given by the Company.
- 10 This Warranty does not cover loss, damage or expense to this appliance caused directly or indirectly by power surges, electrical storm damage or incorrect power current.

Description of the product

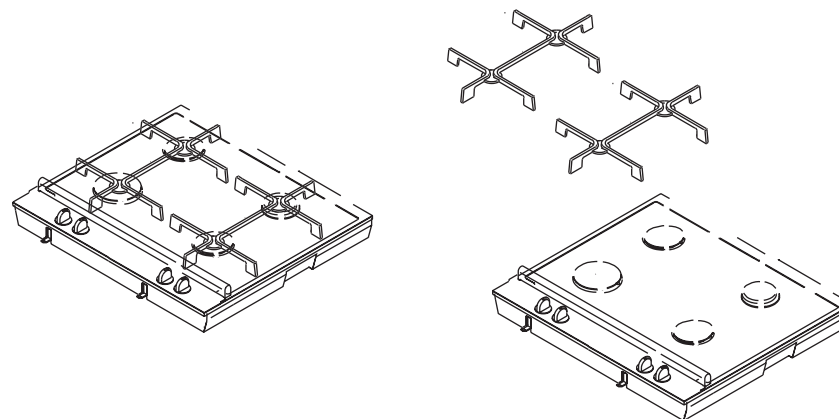
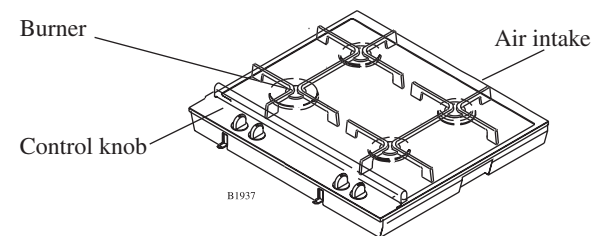

Operations

Burner markings

Signs at each operating knob indicate which burner is to be adjusted with the knob in question.

Back Burner



Front burner



Panel markings

Each operating knob has a ring showing the scale of markings.

Off.



Max. flame



Min. flame

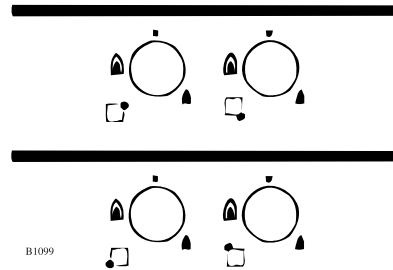

10 This warranty does not cover loss, damage or expense to this appliance caused directly or indirectly by power surges, electrical storm damage or incorrect power current.

11 The Company (and any company related to the Company) will not be liable for any special, incidental or consequential damages or for loss, damage or expense or for personal injury or loss or destruction of property arising directly or indirectly from the use or inability to use this appliance or any of its parts.

12 This warranty applies only to the original buyer.

13 This warranty is the only express warranty given by the Company.

14 If you are the original buyer, please keep your proof of purchase, which will be required, if you request service under this warranty.

15 The Warranty Period is only applicable when your appliance is used at home by you and your family as consumers.

16 Use of this appliance for commercial purposes is covered by this warranty for a period of 3 months from the date of purchase.

FOR SERVICE IN AUSTRALIA

PLEASE CALL 13 13 49

FOR SPARE PARTS IN AUSTRALIA

PLEASE CALL 13 13 50

ELECTROLUX WARRANTY AUSTRALIA

Nothing in this warranty, limits any rights you may have under the Trade Practices Act or any other Commonwealth or State legislation. Such rights cannot be changed by the conditions in this warranty.

Subject to the conditions below, this appliance is warranted by Electrolux Home Products Pty. Ltd. A.B.N. 51 004 762 341, (the "Company"), to be free from defects in materials and workmanship for a period of 24 months following the date of purchase (the "Warranty Period").

Conditions of the warranty:

- 1 During the Warranty Period the Company, or its service agent, will only pay the cost of repairing or replacing all Company parts on your appliance which the Company finds to be defective.
- 2 The Company will decide if there are any defects in material and/or workmanship.
- 3 Light globes, batteries and filters are replaceable parts and are not covered under this warranty.
- 4 This warranty applies only for mainland Australia and Tasmania.
- 5 The appliance must be installed and operated in accordance with

the Company's instructions.

- 6 This warranty does not apply to normal wear and tear, or any service, which is needed after an accident, alteration, negligence, misuse, fire or flood.
- 7 This warranty does not apply to damage caused if your appliance has been dismantled, repaired or serviced by any person other than someone authorised by the Company.
- 8 If you live outside the service area of the Company or one of its service agents, this warranty does not cover the cost of transport of the appliance for service nor the service agent's travelling costs to and from your home.
- 9 If you are required to transport the appliance to the Company or its service agent, you must ensure it is securely packed and insured. The Company does not accept any responsibility for loss or damage of the appliance prior to it being received by the Company or its service agent.

Burner cover/burner ring

Together with the burner ring the burner cover forms a space where the final mixture of gas and air takes place in order to make the gas burn correctly.

Please note: It is consequently very important that the individual burner cover/ring is placed correctly on the burner. The burner ring has been provided with holes for the ignition electrode, and the thermo sensor.

If the burner cover/ring are wrongly placed the burner will operate incorrectly, and the burners may be damaged within at short space of time.

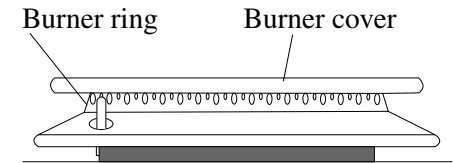

Correct

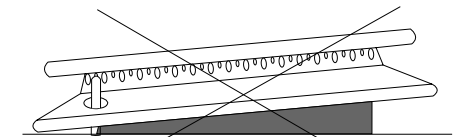

Wrong

Ignition electrode (A)

Each burner has been provided with an ignition electrode. As long as the operating knob is depressed, the automatic ignition will ensure that a spark is emitted between the ignition electrode and the burner cover.

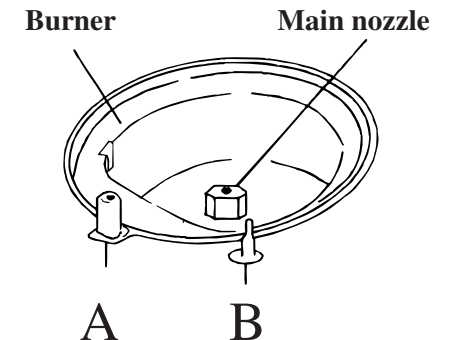

Thermo Sensor (B)

The hob unit features fully-secured gas taps (thermo-fuse) In case the flame goes out, the thermo sensor automatically prevents gas admission after a few seconds (max. 90 seconds).

Note: Gas admission is always allowed while the operation button is pressed - See start-up procedure

Ignition

1. Depress and turn the control knob for the burner to the left to max. flame 🔥 . (Ignition position)
2. The ignition electrode will emit sparks, and when the mixture of gas and air is correct, the burner will be ignited. If it is not possible to connect the unit to mains, a match may be used to ignite the burner.
3. After starting the burner, press the control knob for approx. 10 seconds to activate the automatic thermo-couple (thermo sensor ready).
5. The burner can now be regulated between maximum 🔥 and minimum 🔥



B1557

Service

Symptom:	Solution:
There is no spark when lighting the gas?	Check whether the 240 V connection has been plugged in. The ground fault circuit relay may have switched off. The fuse has blown
When the operating knob is released the gas ring goes out again?	The operating knob has not been depressed long enough, or has not been depressed sufficiently.
The gas ring burns very unevenly?	Ensure the cover has been replaced correctly, e.g. after cleaning.
Any of the following are considered to be abnormal operation and may require servicing: <ul style="list-style-type: none"> * Yellow tipping of burner flame * Sooting up of cooking utensils * Burners not igniting properly * Burners failing to remain alight * Burner/s extinguished by cupboard doors. * Gas valves which are difficult to turn. 	If service is required contact: Electrolux Service Centre; For service within Australia: Please phone 131349 (Australia only). For service within New Zealand: Please phone 0800 106 610 (Free Call New Zealand Only).

Technical data

Type of gas

Adjusted for natural gas: 1,0 kPa
(test point pressure)

Q = Nominal gas consumption NG:
Small burner x 1= 4,0 MJ/h
Medium sized burner x 2= 7,7 MJ/h
Large sized burner x 1= 10,0 MJ/h
Total= 29,4 MJ/h

AUS/NZL:
Convertible to universal LPG (Propane):
2,75 kPa (test point pressure)

Q = Nominal gas consumption universal
LPG:
Small burner x 1= 3,6 MJ/h
Medium sized burner x 2= 7,0 MJ/h
Large sized burner x 1= 10,1 MJ/h
Total= 27,7 MJ/h

Hob is approved in accordance with
AS4551 (AG101) Australian Standard
Domestic Gas Cooking Appliances.
AGA Approval No. 6310

Electrical supply 230/240 V 50 Hz AC,
0,1A max

Ignition= 240 V / 0,6 VA generator

FSD

The unit features fully-secured gas taps
(thermo-fuse).

Radio-noise reduction

This unit observes the current EEC-
directive on radio noise reduction.

Material: Stainless steel, ceramic
glass

Pansupport: Castiron enamelled

Built-in measurements:

Height: 60 mm
Width: 560 mm
Depth: 490 mm

Product measurements:

Height: 45 mm
Width: 580 mm
Depth: 510 mm

Weight: 13 kg

"THIS APPLIANCE MUST BE
CONNECTED TO AN EARTHED
GENERAL PURPOSE OUTLET."

Maintenance and cleaning

Stainless steel surfaces

Perform daily cleaning with a slightly
damp cloth. For more severe soiling,
use a liquid scouring cream. Always
clean the steel in the direction of the
steel finish. To ensure that the steel
retains its shine, it is recommended
that you use a polishing agent for
stainless steel on a regular basis.
Always polish in the direction of the
steel finish (cross-wise).

Never use steel wool, metal sponges or
other abrasive cleaning agents.

Avoid saucepans boiling over. If you
have been so unfortunate as to get
water in the burner this water should
be removed before re-igniting the
burner, e.g. with a no-fluff cloth.

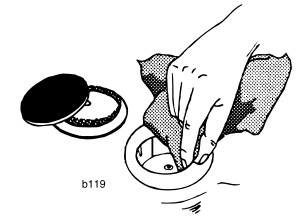

Cleaning of gas burners

Clean the control panel and knobs plus the pan grid, as well as burner caps and rings, with ordinary cleansing agents.

Never use scouring powder, Brillo pads, metal pads or other scouring agents on enamelled or painted surfaces!

Avoid boil-over

If water accidentally gets into the edge of the burner head (boil-over) the water must be removed with a lint-free cloth before the burner is turned on again.

Likewise, caps and grids must be thoroughly wiped off before the gas ring is used again so that the boil-over does not permanently scar the enamel or paint.

Before leaving

The pipe connections should be checked for leaks with soap and water. **Do not** use a naked flame for detecting checks.

Test all burners on high and low flame for flame stability. Test the stability of the low flame when any nearby cupboard doors are used.

When satisfied with the appliance, please instruct the user on the correct method of operation. If the appliance fails to operate correctly after all checks have been made, refer to the authorised service provider in your area.

The units externally measured length

145 mm:

Cooker hood

290 mm:

Two-zone ceramic-top electric hob

Two-burner gas hob

Grill

Fryer

Wok

580 mm:

Four-zone ceramic-top electric hob

Four-burner gas hob.

725 mm:

Four-zone ceramic-top electric hob.

Mounting

Use of Hose Assemblies.

If the appliance is to be installed using a hose assembly, then

1. The hose must be AGA certified to AS/NZS 1869 as class B or class D, and utilised in accordance with requirements of AS 5601 (AG 601).
2. The connection point between the consumer piping and the hose must be accessible with the appliance installed.

Electrical Connection

This appliance is supplied with an 1800mm long flexible supply lead and 3 pin plug. The point of connection is located at the rear and on the underside of the appliance. Connect the appliance to a readily accessible switched general purpose outlet which is adjacent to the appliance.

THIS APPLIANCE MUST BE CONNECTED TO AN EARTHED GENERAL PURPOSE OUTLET.

This appliance must be installed by an authorised person.

This appliance shall be installed in accordance with the manufacturer's installation instructions, local gas fitting regulations, municipal building codes, AS5601 (AG601) Australian Standard - Gas Installations and any other relevant statutory regulations.

Data label

The data label is located on the underside of the hob next to the gas connection. A duplicate data label is supplied to adhere in an accessible area next to the hob. This appliance is suitable for Natural Gas and Universal LPG, ensure that the available gas supply matches the data label.

Ventilation

Ventilation must be in accordance with AS5601 (AG601) Gas installations. In general, the appliance should have adequate ventilation for complete combustion of gas, proper flueing and to maintain temperature of immediate surroundings within safe limits.

Location

Choose a location free of draughts and open doors and clear of combustible materials or other fire hazards. The location should ensure convenience of operation and service.

Any adjoining wall surface situated within 200 mm from the edge of any hob burner must be a suitable noncombustible material for a height of 150 mm for the entire length of the hotplate.

Any combustible construction above the hotplate must be at least 600 mm above the top of the burner and no construction shall be within 450 mm above the top of burner. A minimum depth of 60 mm from the top of the worktop surface must be provided for the hotplate.

Cut-out measurements

One rectangular hole is sawn out for the hob combination chosen. The depth of the cut-out for any unit is: 490 mm
Length of hole = sum of all units' externally measured length, less 20 mm.

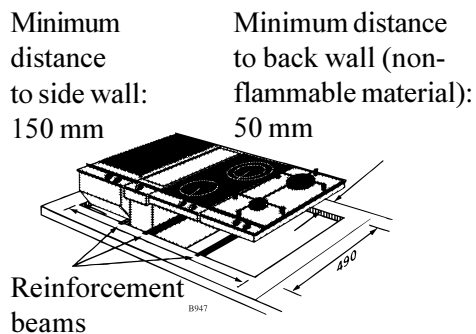

Mounting of Reinforcement Beams

A reinforcement Beam, with supporting flanges at each end, is included with each two-burner unit. For unit combinations, a reinforcement beam must be used between each unit. It is not necessary to attach the reinforcement beam to the table surface, as it is held in place by a specially designed moulding, which is incorporated in the hob units flanges.

Gas installation

The appliance is factory set for Natural Gas. Fit the gas regulator supplied with the appliance to the gas inlet. The location of the gas inlet is approximately 240mm from the right hand side of the appliance and 40mm from the back of the appliance. The connection of the Gas Regulator is 1/2" Gas female thread and the pressure at the test point should be adjusted to 1.00kPa with the large and simmer burners operating at maximum. For Universal LPG connection, the appliance needs to be first converted using the conversion kit and instructions supplied with the appliance.

For Universal LPG the regulator is fitted to the gas inlet of the appliance so that a pressure test point is available. The regulator should be disabled by adjusting the regulator adjusting screw to be fully screwed in, but do not remove the locking nut from the regulator. The supply pressure to the appliance is controlled by the regulator located on the LPG cylinder. This cylinder regulator should be adjusted to give a pressure of 2.75kPa at the appliance inlet with the large and simmer burners operating at maximum

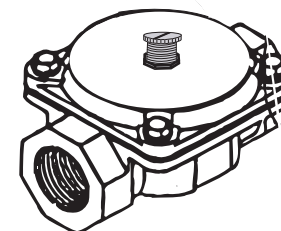

Typical Adjustment for Natural Gas

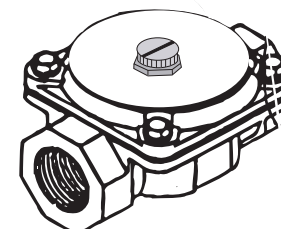

Adjusted for LPG

B2004

3790