

The Thoughtful Design Innovator.

Do you remember the last time you opened a gift that made you say "Oh! How did you know? That's exactly what I wanted!" That's the kind of feeling that the designers at Electrolux seek to evoke in everyone who chooses or uses one of our products. We devote time, knowledge, and a great deal of thought to anticipating and creating the kind of appliances that our customers really need and want.

This kind of thoughtful care means innovating with insight. Not design for design's sake, but design for the user's sake. For us, thoughtful design means making appliances easier to use and tasks more enjoyable to perform, freeing our customers to experience the ultimate 21st century luxury: ease of mind. Our aim is to make this ease of mind more available to more people in more parts of their everyday lives, all over the world.

The "Thinking of you" promise from Electrolux goes beyond meeting the needs of today's consumers. It also means we're committed to making appliances safe for the environment — now and for future generations.

Electrolux. Thinking of you.

Share more of our thinking at www.electrolux.com.au

Thinking of you
Electrolux

Congratulations

Congratulations and thank you for choosing our four-door refrigerator. Our appliances are designed to be easy to use and complimentary to your lifestyle. Before using your new Electrolux appliance we recommend that you read the user manual to understand the product and its benefits.

To avoid the risks that are always present when you use an electric appliance, it is important that the refrigerator is installed correctly and that you read the safety instructions carefully to avoid misuse and hazards.

We recommend that you keep this instruction booklet for future reference and pass it on to any future owners.

After unpacking the refrigerator please check it is not damaged. If in doubt, do not use the product but contact your local Electrolux Service Centre.

Contents

• Four-door refrigerator	ii
• Control panel	iii
• Important safety instructions	1
• Installation	2
• Dimensions	3
• Clearances	3
• Controlling temperature	4
• Timer	4
• Door alarm	4
• Child lock	5
• Express freezing	5
• Holiday mode	5
• Storing food	6
• Care and cleaning	6
• Troubleshooting	7
• Removing door handles	8
• Warranty	9



environmental tip

Information on disposal for users

- Most of the packing materials are recyclable. Please dispose of those materials through your local recycling depot or by placing them in appropriate collection containers.
- If you wish to discard this product, please contact your local authorities and ask for the correct method of disposal.



user manual
four-door refrigerator
(EQE6007SB)



Four-door refrigerator

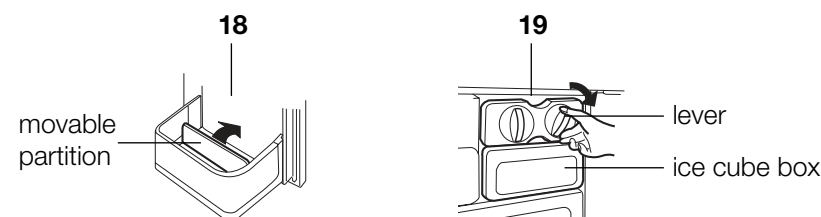
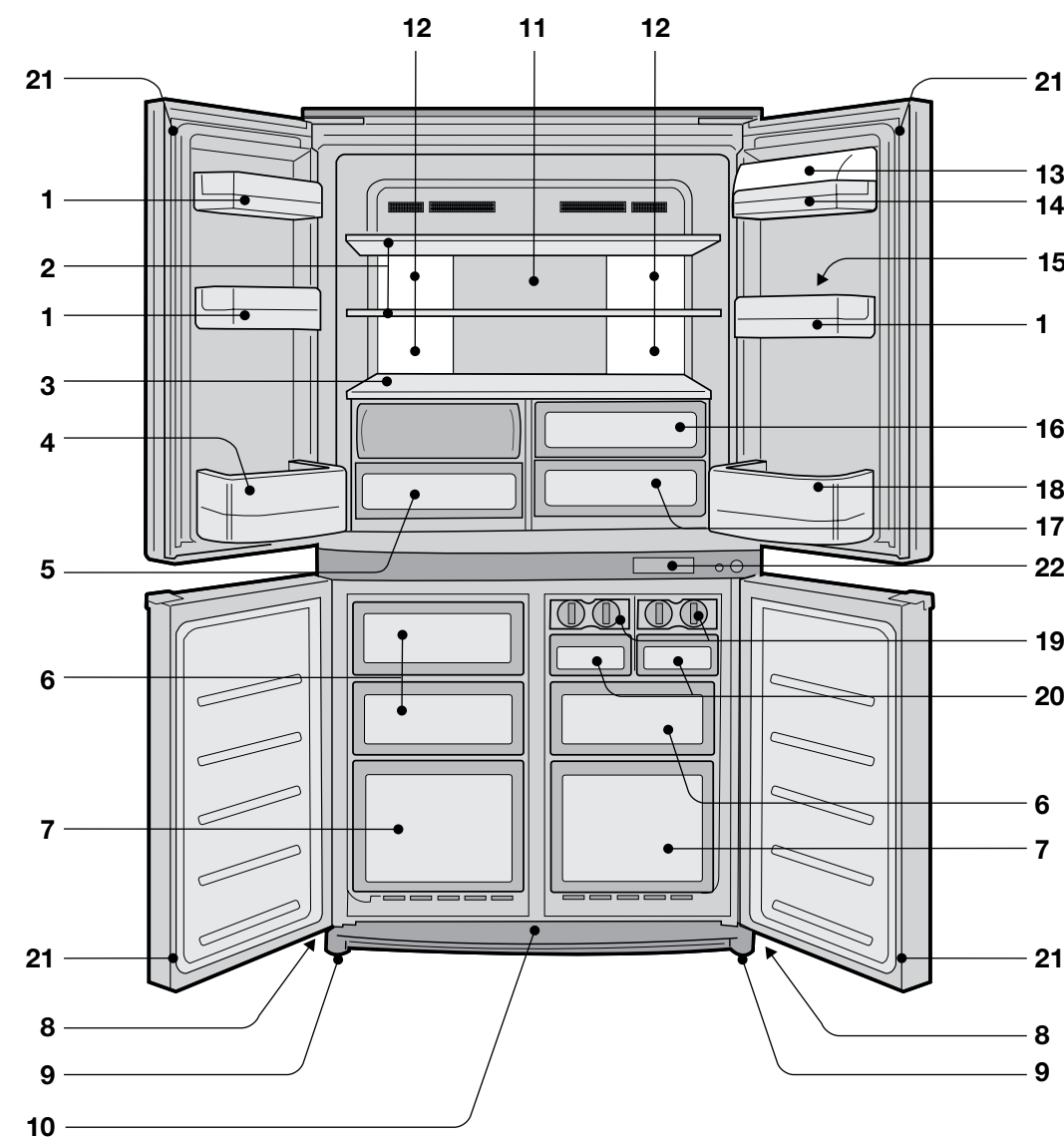

- | | | |
|--------------------------|---------------------------------------|---|
| 1 Door bins | 9 Adjustable feet | 16 Deli compartment |
| 2 Adjustable glass shelf | 10 Kickplate | 17 Chilled compartment |
| 3 Fixed glass shelf | 11 Aluminium panel | 18 Bottle bin (right) |
| 4 Bottle bin (left) | 12 Refrigerator light (4 x 15W lamps) | 19 Twist and serve ice dispenser |
| 5 Vegetable crisper | 13 Dairy bin lid | 20 Ice cube box |
| 6 Freezer drawer (small) | 14 Dairy bin | 21 Magnetic door seal |
| 7 Freezer drawer (large) | 15 Egg tray | 22 Control panel and electronic display |
| 8 Rollers | | |

Control panel

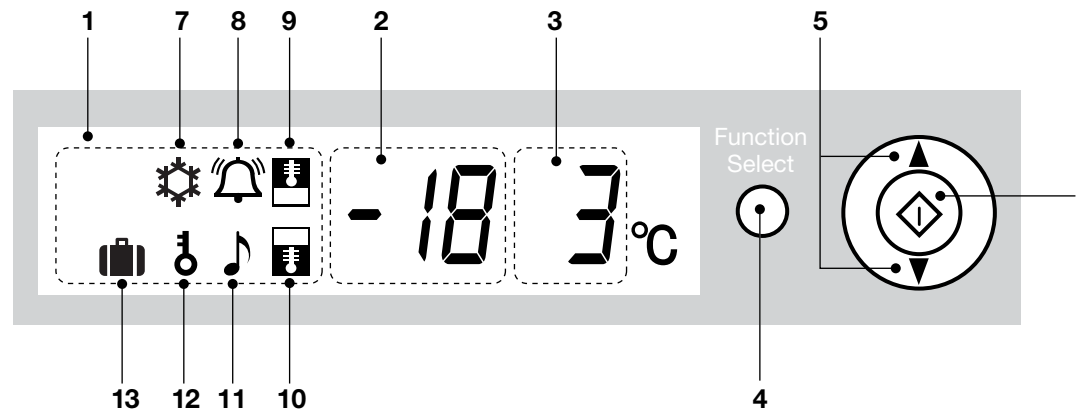

- | | | |
|------------------------------------|------------------------------------|-----------------|
| 1 LCD display | 6 Confirmation button | 11 Door alarm |
| 2 Freezer temperature setting | 7 Express freezing | 12 Child lock |
| 3 Refrigerator temperature setting | 8 Timer | 13 Holiday mode |
| 4 Function select button | 9 Refrigerator temperature control | |
| 5 Setting selector | 10 Freezer temperature control | |

Default setting

When power is turned on the display defaults to:

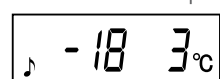

In the event of a power failure, the Timer feature is cancelled and will need to be re-entered if required.

NOTE:

- When no operation is made for 30 seconds, the display will automatically return to the initial content. The backlight will become dark if there is no operation for 3 minutes. The backlight will turn off if there is no operation for 6 minutes.

Defrosting

- The defrosting system incorporates a fully automatic energy efficient defrosting system.
- The defrost water collects in the evaporating pan, where it is evaporated by the heat of the compressor.
- The evaporating pan does not require cleaning or maintenance.

Electrolux Warranty

FOR SALES IN AUSTRALIA AND NEW ZEALAND
APPLIANCE: REFRIGERATION

This document sets out the terms and conditions of the product warranties for Electrolux Appliances. It is an important document. Please keep it with your proof of purchase documents in a safe place for future reference should you require service for your Appliance.

- In this warranty
 - 'acceptable quality' as referred to in clause 10 of this warranty has the same meaning referred to in the ACL;
 - 'ACL' means Trade Practices Amendment (Australian Consumer Law) Act (No.2) 2010;
 - 'Appliance' means any Electrolux product purchased by you accompanied by this document;
 - 'ASC' means Electrolux' authorised serviced centres;
 - 'Electrolux' means Electrolux Home Products Pty Ltd of 163 O'Riordan Street, Mascot, NSW 2020, ABN 51 004 762 341 in respect of Appliances purchased in Australia and Electrolux (NZ) Limited of 3-5 Niall Burgess Road, Mount Wellington, in respect of Appliances purchased in New Zealand;
 - 'major failure' as referred to in clause 10 of this warranty has the same meaning referred to in the ACL and includes a situation when an Appliance cannot be repaired or it is uneconomic for Electrolux, at its discretion, to repair an Appliance during the Warranty Period;
 - 'Warranty Period' means:
 - where the Appliance is used for personal, domestic or household use (i.e. normal single family use) as set out in the instruction manual, the Appliance is warranted against manufacturing defects in Australia and New Zealand for 24 months and for the Appliance's compressor, condenser, evaporator and drier, an additional 36 months parts only warranty applies, following the date of original purchase of the Appliance;
 - where the Appliance is used for commercial purposes (including being used to directly assist a business or where the Appliance is used in a multi-family communal or share type environment), the Appliance will then be warranted against manufacturing defects in Australia for 3 months and in New Zealand for 3 months, following the date of original purchase of the Appliance.
 - 'you' means the purchaser of the Appliance not having purchased the Appliance for re-sale, and 'your' has a corresponding meaning.
- This warranty only applies to Appliances purchased and used in Australia or New Zealand and is in addition to (and does not exclude, restrict, or modify in any way) any non-excludable statutory warranties in Australia or New Zealand.
- During the Warranty Period Electrolux or its ASC will, at no extra charge if your Appliance is readily accessible for service, without special equipment and subject to these terms and conditions, repair or replace any parts which it considers to be defective. Electrolux or its ASC may use remanufactured parts to repair your Appliance. You agree that any replaced Appliances or parts become the property of Electrolux. This warranty does not apply to light globes, batteries, filters or similar perishable parts.
- Parts and Appliances not supplied by Electrolux are not covered by this warranty.
- You will bear the cost of transportation, travel and delivery of the Appliance to and from Electrolux or its ASC. If you reside outside of the service area, you will bear the cost of:
 - travel of an authorised representative;
 - transportation and delivery of the Appliance to and from Electrolux or its ASC,
 In all instances, unless the Appliance is transported by Electrolux or an

Electrolux authorised representative, the Appliance is transported at the owner's cost and risk while in transit to and from Electrolux or its ASC.

- Proof of purchase is required before you can make a claim under this warranty.
- You may not make a claim under this warranty unless the defect claimed is due to faulty or defective parts or workmanship. Electrolux is not liable in the following situations (which are not exhaustive):
 - The Appliance is damaged by:
 - accident
 - misuse or abuse, including failure to properly maintain or service
 - normal wear and tear
 - power surges, electrical storm damage or incorrect power supply
 - incomplete or improper installation
 - incorrect, improper or inappropriate operation
 - insect or vermin infestation
 - failure to comply with any additional instructions supplied with the Appliance;
 - The Appliance is modified without authority from Electrolux in writing;
 - the Appliance's serial number or warranty seal has been removed or defaced;
 - the Appliance was serviced or repaired by anyone other than Electrolux, an authorised repairer or ASC.
- This warranty, the contract to which it relates and the relationship between you and Electrolux are governed by the law applicable where the Appliance was purchased. Where the Appliance was purchased in New Zealand for business purposes the Consumer Guarantee Act does not apply.
- To the extent permitted by law, Electrolux excludes all warranties and liabilities (other than as contained in this document) including liability for any loss or damage whether direct or indirect arising from your purchase, use or non use of the Appliance.
- For Appliances and services provided by Electrolux in Australia, the Appliances come with a guarantee by Electrolux that cannot be excluded under the Australian Consumer Law. You are entitled to a replacement or refund for a major failure and for compensation for any other reasonably foreseeable loss or damage. You are also entitled to have the Appliance repaired or replaced if the Appliance fails to be of acceptable quality and the failure does not amount to a major failure. The benefits to you given by this warranty are in addition to your other rights and remedies under a law in relation to the Appliances or services to which the warranty relates.
- At all times during the Warranty Period, Electrolux shall, at its discretion, determine whether repair, replacement or refund will apply if an Appliance has a valid warranty claim applicable to it.
- For Appliances and services provided by Electrolux in New Zealand, the Appliances come with a guarantee by Electrolux pursuant to the provisions of the Consumer Guarantees Act, the Sale of Goods Act and the Fair Trading Act.
- To enquire about claiming under this warranty, please follow these steps:
 - carefully check the operating instructions, user manual and the terms of this warranty;
 - have the model and serial number of the Appliance available;
 - have the proof of purchase (eg an invoice) available;
 - telephone the numbers shown below.
- You accept that if you make a warranty claim, Electrolux and its ASC may exchange information in relation to you to enable Electrolux to meet its obligations under this warranty.

Important Notice

Before calling for service, please ensure that the steps listed in point 13 above have been followed.

<p>FOR SERVICE or to find the address of your nearest state service centre in Australia PLEASE CALL 13 13 49 <small>For the cost of a local call (Australia only)</small></p>	<p>SERVICE AUSTRALIA Electrolux ELECTROLUX HOME PRODUCTS www.electrolux.com.au</p>	<p>FOR SPARE PARTS or to find the address of your nearest state spare parts centre in Australia PLEASE CALL 13 13 50 <small>For the cost of a local call (Australia only)</small></p>
<p>FOR SERVICE or to find the address of your nearest authorised service centre in New Zealand FREE CALL 0800 10 66 10 <small>(New Zealand only)</small></p>	<p>SERVICE NEW ZEALAND Electrolux ELECTROLUX HOME PRODUCTS www.electrolux.co.nz</p>	<p>FOR SPARE PARTS or to find the address of your nearest state spare parts centre in New Zealand FREE CALL 0800 10 66 20 <small>(New Zealand only)</small></p>

Important safety instructions

Please read and save these instructions

This Use & Care Manual provides specific operating instructions for your model. Use your refrigerator only as instructed in this manual. These instructions are not meant to cover every possible condition and situation that may occur. Common sense and caution must be practiced when installing, operating and maintaining any appliance.

Important: Before you install your refrigerator, PLEASE CHECK FOR ANY DAMAGE OR MARKS. If you find that the refrigerator is damaged or marked, you must report this within 7 days if you wish to claim for damage / marks under the manufacturers warranty. This does not affect your statutory rights.

The symbols you will see in this booklet have these meanings:



warning

This symbol indicates information concerning your personal safety

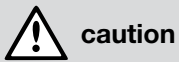

caution

This symbol indicates information on how to avoid damaging your refrigerator



tips and information

This symbol indicates tips and information about use of the refrigerator



environmental tip

This symbol indicates tips and information about economical and ecological use of the refrigerator

Meanings of symbols used in this manual are shown below:



This symbol indicates never to do this



This symbol indicates always do this



warning

- If pressurised aerosol containers bear the word 'flammable' and/or a small flame symbol, do not store them inside any refrigerator. If you do so you may cause an explosion. 
- When you dispose of refrigerators and freezers, remove any doors. Children can suffocate if they get trapped inside.
- This refrigerator contains insulation formed with flammable blowing gases. Avoid safety hazards by carefully disposing of this appliance.
- Don't use a steam cleaner. If live components come into contact with condensing steam, they may short-circuit or cause an electric shock.



warning

This appliance is not intended for use by persons (including children) with reduced physical, sensory or mental capabilities, or lack of experience and knowledge, unless they have been given supervision or instruction concerning use of the appliance by a person responsible for their safety. Children should be supervised to ensure that they do not play with the appliance.



warning

- ✓ The appliance must be plugged into its own dedicated 220-240V, 50Hz AC electrical outlet.
- ✓ Ensure that the electric outlet is properly earthed to ground. Consult a qualified electrician if you are unsure.
- ⊘ Do not use an extension cord or adapter plug.
- ✓ If the power cord is damaged, it should be replaced by a service technician or a qualified person.
- ✓ Unplug the appliance before cleaning and before changing the light bulb to avoid electric shock.
- ⊘ Never unplug the appliance by pulling on the power cord. Always grip the plug firmly, and pull straight out of the receptacle to prevent damaging the power cord.
- ✓ Choose a location that is not too cold - the temperature should be above 10°C.
- ✓ Put the appliance in a dry place, avoiding areas of high moisture or humidity.
- ⊘ Don't put the appliance in frosty or unprotected areas, for example in a garage or on a verandah.
- ⊘ Don't put the appliance in direct sunlight.
- ⊘ Don't put the appliance near stoves, fires or heaters.
- ✓ When transporting and installing the refrigerator, care should be taken to ensure that no parts of the refrigerating circuit are damaged.
- ⊘ Do not damage the refrigerant circuit.
- ✓ Keep ventilation openings in the appliance enclosure or in the built-in structure clear of obstruction.

When correctly installed, your appliance should:

- have adequate clearance to the back and sides for air circulation (refer to page 3).
- be aligned to the surrounding cupboards.



warning

It is important to use your refrigerator safely. This means you need to supervise young children and infirm persons when they use it. You need to make sure that young children do not play with the refrigerator. Follow the tips below:

- ⊘ Never let children play with the refrigerator.
- ⊘ Never store fizzy drinks in the freezer compartment.
- ⊘ Never try to repair the refrigerator yourself.
- ⊘ Never use electric heaters or dryers to defrost the freezer because you can receive an electric shock.
- ⊘ Never use electrical appliance inside the food storage compartments of the appliance, unless they are of the type recommended by the manufacturer.
- ⊘ Do not use mechanical devices or other means to accelerate the defrosting process other than those recommended by the manufacturer.



warning

R600a refrigerant warning

This appliance contains a small quantity of environmentally friendly, but flammable, non-synthetic R600a refrigerant:

- Ensure that the tubing of the refrigerant circuit is not damaged during transportation and installation.
- Leaking refrigerant may cause eye injuries or ignite.
- The room for installing appliance must be at least 1m³ per 8g of refrigerant. The amount of refrigerant in the appliance can be found on the rating plate inside the appliance.

Installation

- To ensure adequate ventilation for your refrigerator, it is recommended to provide space of 60mm on both sides and at the back, and space of 90mm above the refrigerator. Insufficient spacing will decrease cooling efficiency, increase energy consumption and may reduce the life of the unit (see page 3).
- Using the two front adjustable feet, ensure that the refrigerator is positioned firmly and level on the floor.

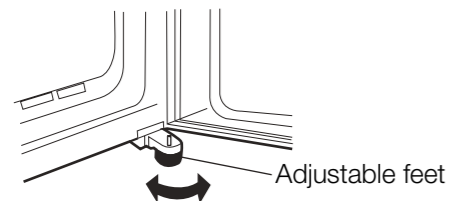

- Using the adjustable feet, raise the front of the unit so it leans back slightly, this will assist in door closing. Make final adjustments to ensure that the doors are correctly aligned.

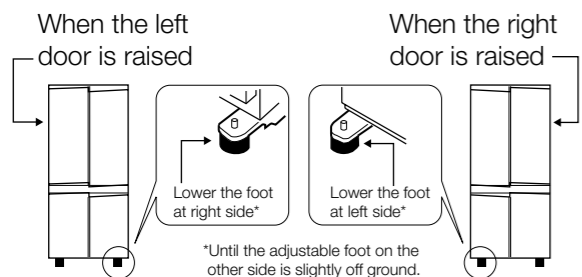

- Remove the 4 screws from the bottom of the refrigerator and use these to fit the kickplate (supplied inside the refrigerator compartment).

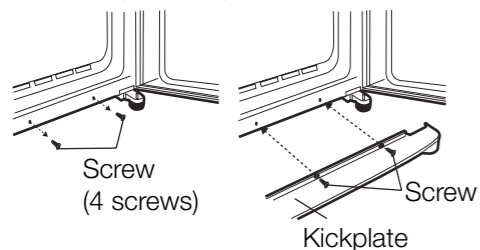

- Connect the power plug to a 240 volt 10 amp power point.

NOTES:

- Position your refrigerator so that the plug is accessible.
- Keep your refrigerator out of direct sunlight.
- Do not place next to a heat generating appliance.
- This refrigerator is designed for indoor use only – do not place the unit on an unsealed surface.
- To avoid vibration and misalignment of the doors, the unit must be level. Place the unit on a solid flat surface. Uneven floors eg. slate, tiles and floorboards, can cause the unit to sag over time causing the doors to become misaligned.
- If the mains power is switched on when the door is open, the door alarm will sound. Close the door to stop the alarm.

When transporting

- Using the rollers, it is possible to move back and forth. Carry the refrigerator by holding the holding devices located on the rear and bottom.

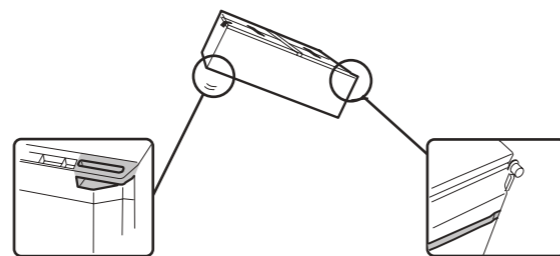

Before using your refrigerator

- Clean the inside parts with a cloth soaked in warm water. If soapy water is used, wipe it off thoroughly.

Dimensions

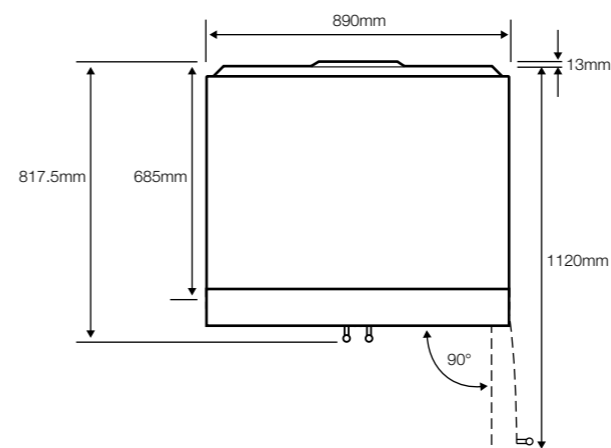
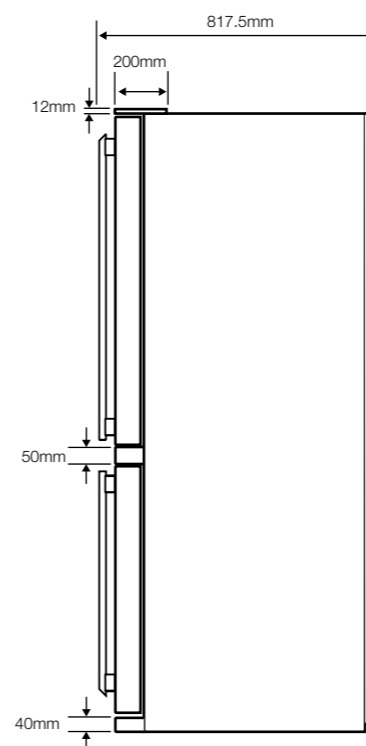
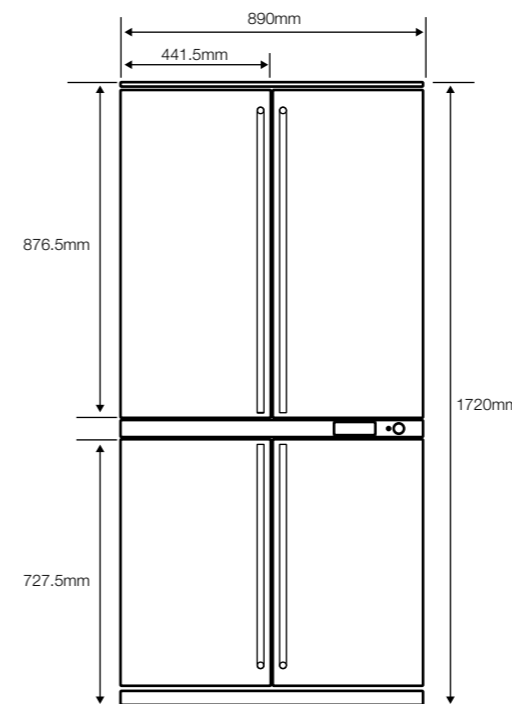

Clearances

Recommended clearances

These are the recommended minimum clearances.

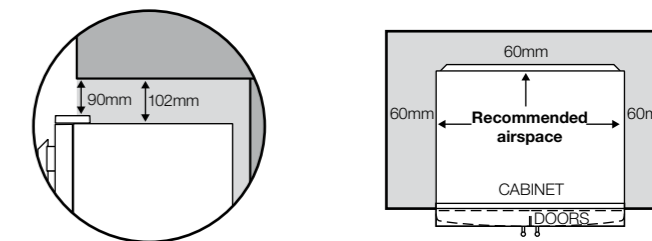

NOTE:

Doors are designed to sit proud of cabinetry (not flush). The clearances shown above are the recommended minimum clearances. For optimum product operation, it is recommended that the clearance at the rear should not exceed 75mm.

When positioned in a corner area, spacing of at least 325mm on the sides will allow the doors to open enough to enable removal of the crisper bins and shelves.

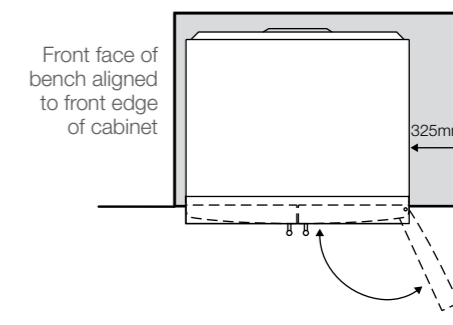

Technical data

Refer to data label on the rear of the appliance for details.

Controlling temperature

The refrigerator controls its temperature automatically. However, if needed, adjust the temperature as follows.

Refrigerator compartment

- 1 Press the “Function select” button and select the Refrigerator temperature setting  icon.

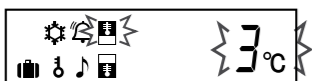

- 2 Press the ▲/▼ button to select the desired temperature. (▲ to increase, ▼ to decrease)



- 3 Press the  button to confirm.

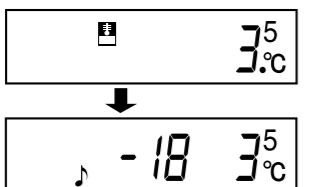

Adjustable between 0° and 6°C in steps of 0.5°

tips and information

For normal operation, the fridge temperature should be set to 3°C. Adjust higher or lower to suit your needs.

Freezer compartment

- 1 Press the “Function select” button and select the Freezer temperature setting  icon.

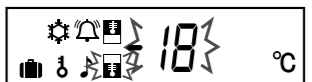

- 2 Press the ▲/▼ button to select the desired temperature. (▲ to increase, ▼ to decrease)

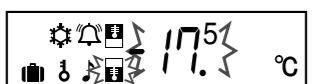

- 3 Press the  button to confirm.

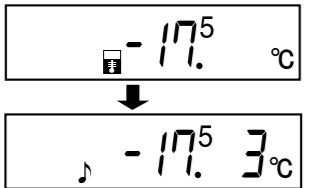

Adjustable between -13° and -21°C in steps of 0.5°

tips and information

For normal operation, the freezer temperature should be set to -18°C. Adjust higher or lower to suit your needs.

Timer

The timer can be set for up to 99 minutes and 30 seconds, in intervals of 30 seconds.

- 1 Press the “Function select” button and select the Timer  icon. The previous timer entry is displayed.



- 2 Press the ▲/▼ button to select the time. (▲ to increase, ▼ to decrease). Hold the button down to set the timer more quickly.



- 3 Press the  button to confirm. The timer will start. The countdown will begin. When the set time is reached, the end tone will sound (for about 30 seconds).

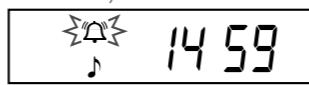

To stop the end tone, press 

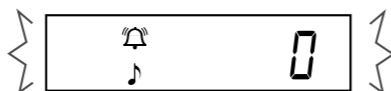

To cancel the timer

- 1 Press the “Function select” button and select the Timer  icon.



- 2 Press the  button.

Door alarm

An alarm will sound momentarily if a door is left open for approximately 1 minute (60 seconds). If a door is left open for 3 minutes, the alarm will sound continuously.

To cancel operation

- 1 Press the “Function select” button and select the Door Alarm  icon.

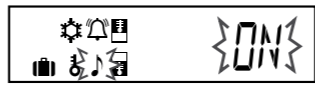



- 2 Press the ▲/▼ button to select “OFF”.

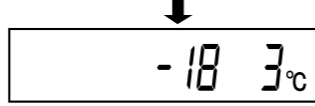

- 3 Press the  button to confirm.



To start operation

- 1 Press the “Function select” button and select the Door Alarm  icon.
- 2 Press the ▲/▼ button to select “ON”.
- 3 Press the  button to confirm.

Child lock

The child lock can be turned on to prevent children tampering with the controls.

- 1 Press the “Function select” button and select the Child Lock  icon.



- 2 Press the ▲/▼ button to select “ON”.

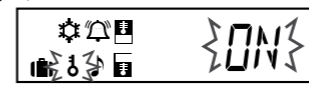

- 3 Press the  button to confirm.

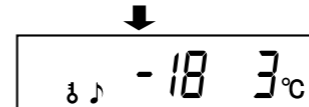
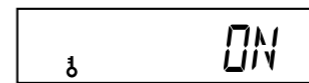

To cancel operation

- 1 Press the “Function select” button continuously for 2 seconds or more.



- 2 Press the ▲/▼ button to select “OFF”.

- 3 Press the  button to confirm.

Express freezing

High-quality frozen foods can be made using this feature. Convenient for home-freezing of small food items.

- 1 Press the “Function select” button and select the Express freezing  icon.



- 2 Press the ▲/▼ button and select “ON”.

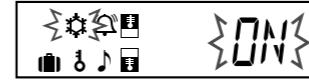

- 3 Press the  button.

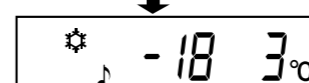

Express Freezing ends automatically in approximately 2 hours (the icon disappears).

To cancel operation

Select “OFF” in step 2.

Notes:

- The time taken to freeze the item will depend on the size, shape and type. For best results, keep items as small as possible.
- Express Freezing may take a little longer if the refrigerator is automatically defrosting.
- Avoid opening the door as much as possible during operation of this feature.

Holiday mode

Use this power saving feature when going away for extended periods.

- 1 Press the “Function select” button and select the Holiday mode  icon.

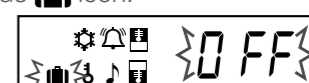

- 2 Press the ▲/▼ button and select “ON”.

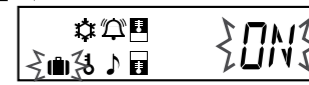

- 3 Press the  button.

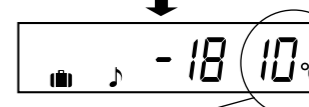

The temperature inside the refrigerator compartment will be adjusted to 10°C. The temperature in the freezer is not changed.

To cancel operation

Select “OFF” in step 2.

Note:

In Holiday Mode, the life of the food in the refrigerator compartment may be reduced to 1/2 or 1/3 of normal. Before going away for extended periods of time, we recommend removing all perishable foods from the refrigerator, before setting this feature.

Storing food

Refrigeration reduces the rate of food spoilage. To maximise the shelf life of perishable food products, ensure that the food is of the freshest possible quality. The following is a general guide to help promote longer food storage.

Fruit and vegetables

To minimise moisture loss, fruit and vegetables should be loosely enclosed in a plastic material (e.g. wrap, bags) and placed in the Vegetable crisper or the Chilled compartment. Those fruits and vegetables with thick skins do not require wrapping.



Dairy products and eggs

- Most dairy products have a use by date on the outer packaging which indicates the recommended temperature and expected life of the product.
- Eggs should be stored in the egg tray.



Meat, fish and poultry

- Place on a plate or dish and cover with paper or plastic wrap.
- For larger cuts of meat, fish or poultry, place to the rear of the shelves.
- Ensure all cooked food is wrapped securely or placed in an airtight container.

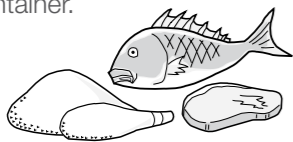

NOTES:

- Evenly place the food on the shelves to allow the cooling air to circulate efficiently.
- Hot foods should be cooled before storing. Storing hot foods increases the temperature in the unit and increases the risk of food spoilage.
- Do not block the outlet and inlet of the cool air circulating circuit with foods or containers; otherwise the foods will not be evenly cooled throughout the refrigerator.
- Do not place food directly in front of cold air outlet. This may lead to the food freezing.

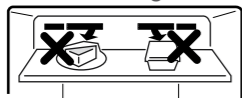

For best freezing

- Food should be fresh.
- Freeze small quantities of food at a time to freeze them quickly.
- Food should be properly stored in containers or freezer bags. Air should be removed if possible and seal tightly.
- Evenly place the food in the freezer.
- Label bags or containers to keep an inventory of frozen food.

Care and cleaning

Some household cleaning chemicals can cause cracks, splits or discolouration on the inside surface of the refrigerator and door liner. **Only use diluted dishwashing liquid** and ensure that all plastic is wiped with fresh water after cleaning.

Alkaline detergents may affect the aluminium parts of the door handle, causing it to tarnish.

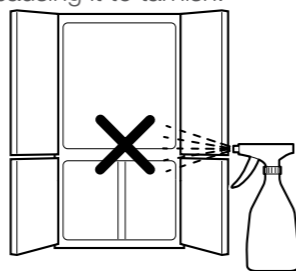

- 1 Remove the shelves and bins from the cabinet and door. Wash them in warm soapy water; rinse in clean water and dry.
- 2 Clean the inside with a cloth soaked in warm soapy water. Then use cold water to wipe off the soapy water.
- 3 Wipe the exterior with a soft cloth each time it is soiled.
- 4 Clean the magnetic door seal with a toothbrush and warm soapy water.
- 5 Wipe the control panel with a dry cloth.

Notes:

- Do not use hot water, household cleaning powders, creams or spray-on cleaning products or any other cleaning products such as mineral turpentine, methylated spirits, thinners, petrol etc. These may damage your refrigerator and may void any warranty.
- If undiluted detergent is used or soapy water is not wiped off thoroughly, cracking of plastic parts can result.
- Wipe any spills from the refrigerator immediately, acid or alkaline in the food can cause cracking and staining of plastic parts.
- The glass shelves weigh approximately 3kg each. Hold firmly when removing from cabinet or carrying.
- Wipe any spills from the control panel immediately, liquid ingress can damage the electronics.

Troubleshooting

If you think something may be wrong with your refrigerator, you can carry out some easy checks before calling for service. You may locate the problem, sparing yourself from inconvenience and saving time and money.



caution

The glass shelves weigh approximately 3kg each. Hold firmly when removing from the cabinet or when carrying.

problem	solution
When your appliance is not operating	<ul style="list-style-type: none"> • Check that the power cord is plugged into the power outlet properly and that the outlet is switched 'ON'. • Try running another appliance from the power outlet. If no power is coming from the outlet you may have blown a fuse or tripped a circuit of your household power supply. • Try adjusting the temperature control to a slightly "colder" position. • It is normal for the freezer fan NOT to operate during the automatic defrost cycle, or for a short time after the refrigerator is switched on.
When there is refrigerator noise	<p>Modern refrigerators/freezers with increased storage capacity use high speed compressors. These can provide a seemingly high level of sound which is quite normal. Normal operational sounds include:</p> <ul style="list-style-type: none"> • Occasional gurgling, similar to water boiling. • Air flow noise (air circulates because of a small fan). • A popping noise heard during automatic defrost. • A clicking noise heard just before the compressor starts (this is merely the automatic switching action of the temperature control, turning the compressor on or off). <p>Other strange sounds may mean that you need to check and take action. For example, noises may mean that:</p> <ul style="list-style-type: none"> • The cabinet is not level. • The floor is uneven or weak. • Bottles are badly placed and rattling. • There are vibrations from an object on top of or behind or beside the refrigerator. • The back of the refrigerator cabinet is touching the wall. <p>Remember it is quite normal for noise to seem louder just after the refrigerator starts operating.</p>
If there are odours inside the refrigerator	<ul style="list-style-type: none"> • The interior may need cleaning. • Some foods produce odours. • Some containers and wrapping can cause odours. • Ask yourself if the odour started about the same time you started storing something unusual.

When the motor seems to run more than expected	<p>Your new refrigerator provides you with large capacities in both the refrigerator section and the separate freezer. It is normal for the motor to operate frequently. However, to keep operation to a minimum, check the following:</p> <ul style="list-style-type: none"> • Are doors kept open too long or too often? • Are controls set too cold? See "Controlling temperature". • Have large amounts of warm food just recently been stored? Summer, festive seasons and holidays usually mean a lot more work for your refrigerator. • If the day is hot or the room is very warm, the refrigerator will need to run more than normal. • The refrigerator will run more than normal just after you install it or when it has been turned off for a long time.
If the temperature in the refrigerator is too warm	<ul style="list-style-type: none"> • Check that the refrigerator has enough clearance at the sides, back and top. Refer to the installation Instructions at the front of this booklet. • Refer to "Controlling temperature". • You may have kept the door open too long or too frequently. • Food containers or packaging may be holding a door open.
If the temperature in the refrigerator is too cold	<ul style="list-style-type: none"> • Refer to "Controlling temperature". • Increase the temperature to avoid high energy consumption.
If heavy frosting occurs in the freezer	<p>Make sure you fully close the freezer and fridge doors. If the doors are left partly open a heavy frost will coat the inside of the freezer. If a frost develops, remove it. Take care to properly close the doors and the frost will not reoccur.</p>
If water droplets form on the aluminium panel	<p>This is normal as the panel is cooled from the rear, therefore indirectly cooling the refrigerator compartment. It is normal for water droplets to form on this panel under humid weather conditions.</p>

If you still require service

If you have a problem, and the problem persists after you have made the checks mentioned above, contact your nearest Electrolux approved Service Centre or the dealer you bought the refrigerator from. Be ready to quote the model number, which is stated on the label inside the refrigerator compartment.

If a refrigerator lamp blows

The lamp should only be replaced by a service centre approved by Electrolux.

Switching off your refrigerator

If the refrigerator needs to be switched off for an extended period, the following steps should be taken to reduce the symptoms of mould:

- 1 Remove all food.
- 2 Remove the power plug from the power point.
- 3 Clean and dry the interior thoroughly.
- 4 Ensure that all the doors are wedged open slightly for air circulation.

Removing door handles

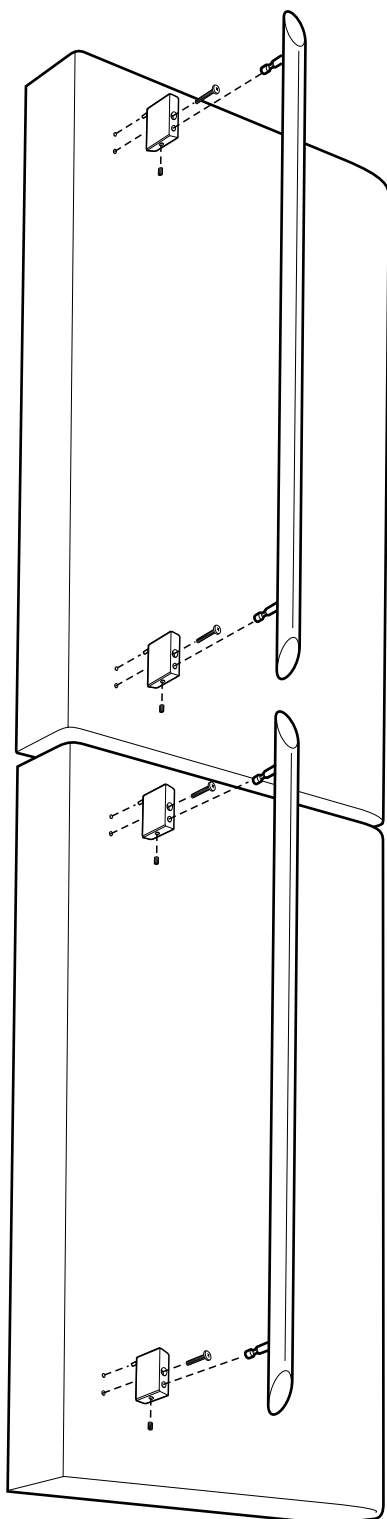

If you need to remove the handles from your door, please follow the instructions below.

- 1 Use a 2.5mm allen key to remove the grub screw from the underside of the handle pedestals.

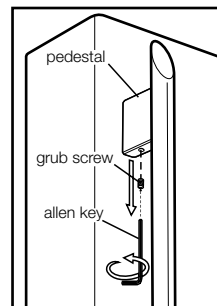

- 2 When the grub screws have been removed from both of the pedestals, the handle can be pulled away from the pedestals.

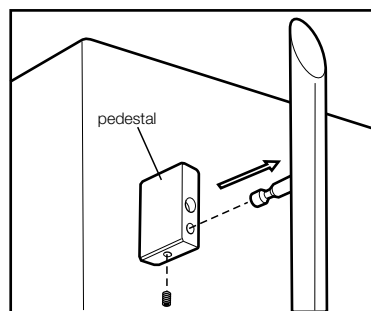

- 3 The pedestals can be removed from the door (if necessary). Remove the phillips head screw and pull the mounting block away from the door.

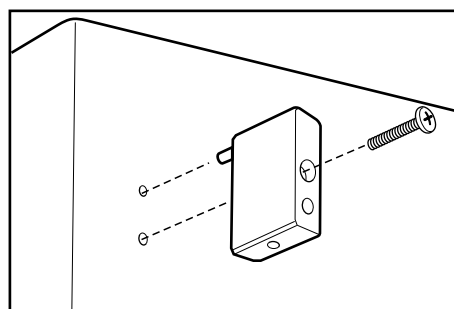

To re-attach the handles, follow the instructions above in reverse.