

600-900 Canopy Installation and Operation Manual

The instructions in this manual are for cooker hood models: CS601S, CS602S, CS902S, CS901S, WRF600, WRF600CS, WRF900CS, WRG630CW, WRG630CS, WRG930CW, WRG930CS, RCD690S, RCD990S

These cooker hoods are domestic appliances which have been manufactured and tested to comply with Australian and New Zealand Standard AS/NZS 3350.2.31.

These appliance are intended to be used in household and similar applications such as: Staff kitchen areas in shops, offices and other working environments; Farm Houses; By clients in hotels, motels and other residential type environments; Bed and breakfast type environments.

Safety Warnings

- This appliance is not intended for used by persons (including children) with reduced physical, sensory or mental capabilities, or lack of experience and knowledge, unless they have been given supervision or instruction concerning use of the appliance by a person responsible for their safety.
- Children should be supervised to ensure that they do not play with the appliance.
- Ensure the cooker hood is switched off before carrying out maintenance, to avoid any possibility of electric shock.
- Grease filters must be removed every four weeks (maximum) for cleaning to reduce the risk of fire.
- Do not flamb'e under the cooker hood.
- This cooker hood is not recommended for barbeques.
- The exhaust air from the cooker hood must not be discharged into any heating flue, which may carry combustion products from other sources.
- Exhaust air must not be discharged into a wall cavity, unless the cavity is designed for the purpose.
- There must be adequate ventilation of the room when the cooker hood is used at the same time as appliances burning gas or other fuels.
- Always cover lit gas burners with pots or pans when the cooker hood is in use.
- Always switch off gas burners before you remove pots or pans.
- CAUTION: Accessible parts may become hot when used with cooking appliance.
- Regulations concerning the discharge of air have to be fulfilled.

Cleaning

Wipe the cooker hood body and ue with a sponge or soft cloth soaked in warm soapy water. Do not use oven cleaners or other abrasive materials.

Electrical Connection

- Check that the mains voltage matches with the voltage on the data plate inside the cooker hood.
- Check that the installation complies with standards of local gas and electricity authorities.
- If the supply cord is damaged, it must be replaced by the manufacturer or its service agent or a similarly qualied person in order to avoid a hazard.

Accessories

- Use 125mm round exhaust ducting for best performance.
- When using flexible duct always install duct with the wire helix pulled taut to minimise pressure loss.
- Try to keep exhaust duct short and straight.
- Keep bends in the exhaust duct to a minimum.
- Do not reduce the size or restrict exhaust duct.

DUCTING ACCESSORIES

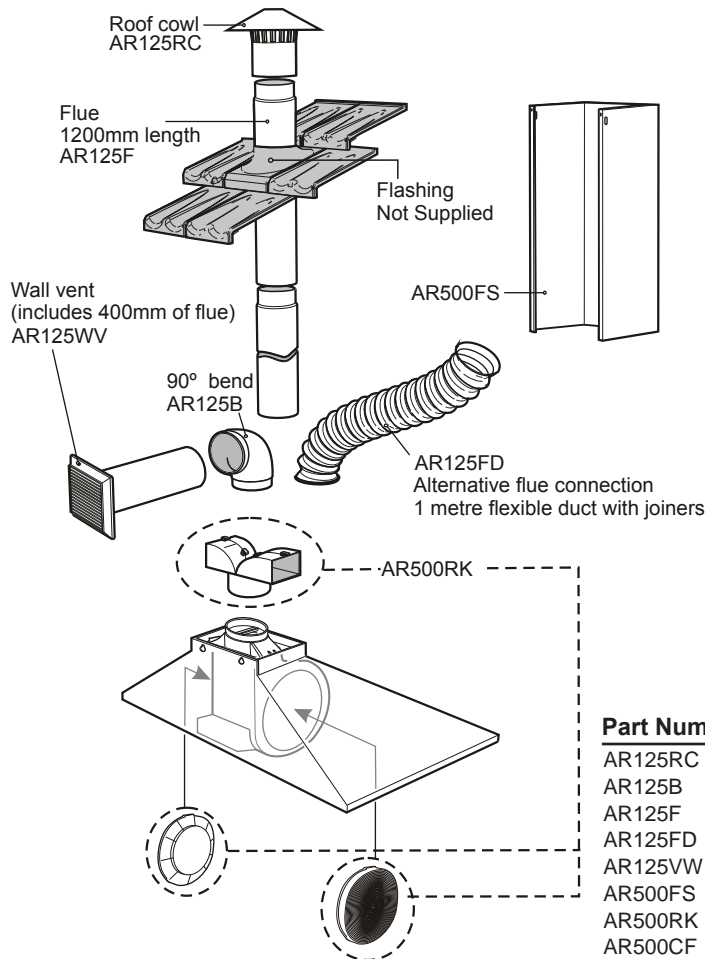

Part Numbers:

Description:

AR125RC	Roof Cowl
AR125B	90° Bend
AR125F	Flue 1200mm Long
AR125FD	Flexible Duct - 1 Metre Long When Expanded
AR125WV	Wall Vent Kit
AR500FS	Extra Length Flue Cover 1100mm Length Brushed Stainless Steel
AR500RK	Recirculating Kit
AR500CF	Replacement Carbon Filters

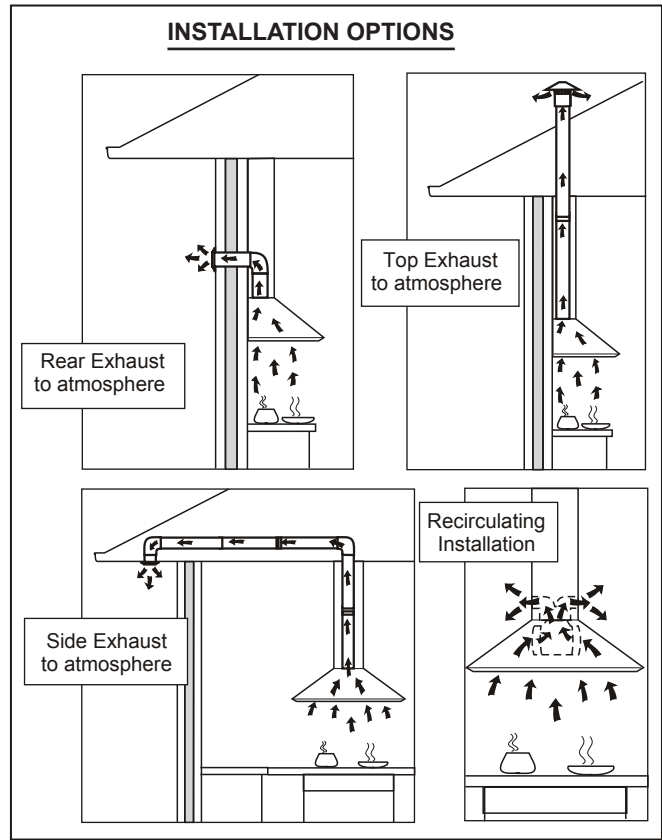

Warning: Failure to install the screws or xing device in accordance with these instructions may result in electrical hazards.

COMPONENTS LIST

- 1 body assembly with grease filters (900-3 grease filters / 600-2 grease filters)
- 1 telescopic flue cover set
- 2 cover flue mounting brackets
- 1 instruction book
- 1 plastic bag containing screws for fixing telescopic flue covers
- 1 plastic duct transition: oblong to round

COMPONENTS NOT INCLUDED

- Fixings required to attach cover flue mounting brackets to wall
- Fixings required to attach the cooker hood to wall

INSTALLING THE COOKER HOOD

Before installing the cooker hood, peel off any protective plastic covering.

Remove polystyrene packaging from inside behind fan motor. (Diagrams C)

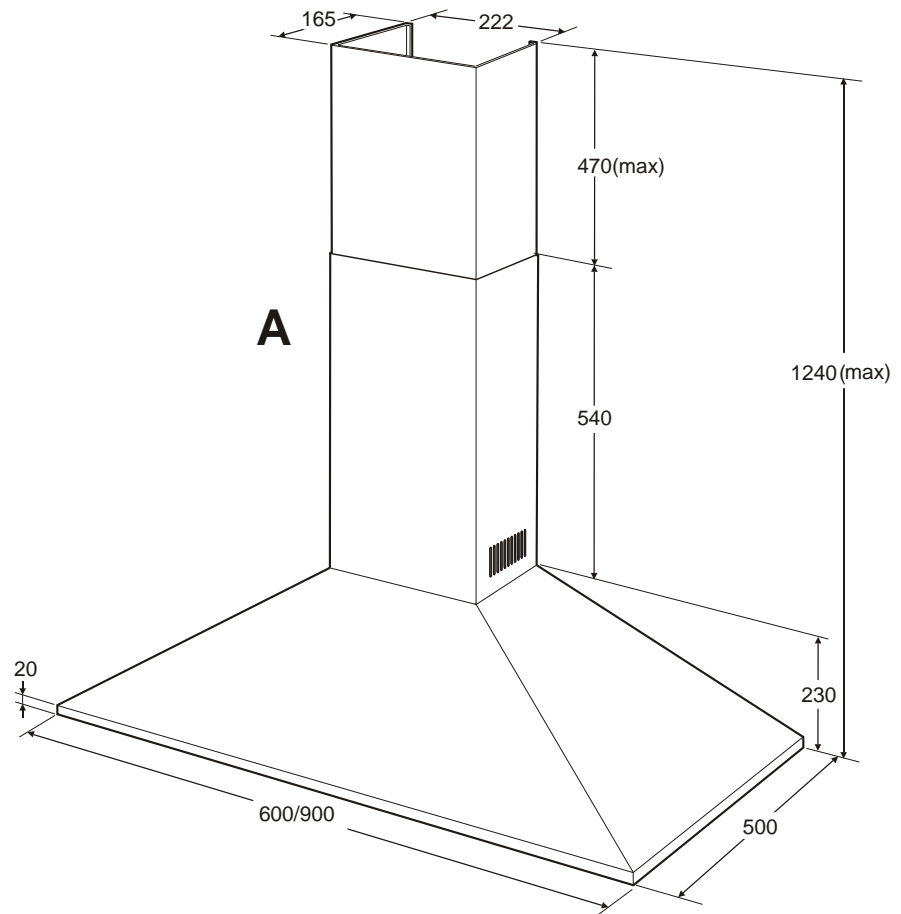
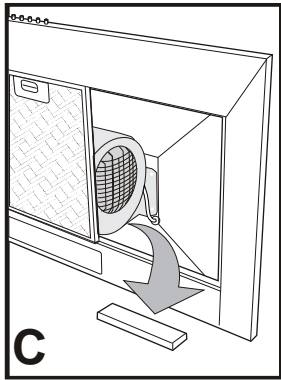

DIMENSIONS ARE IN MILLIMETRES

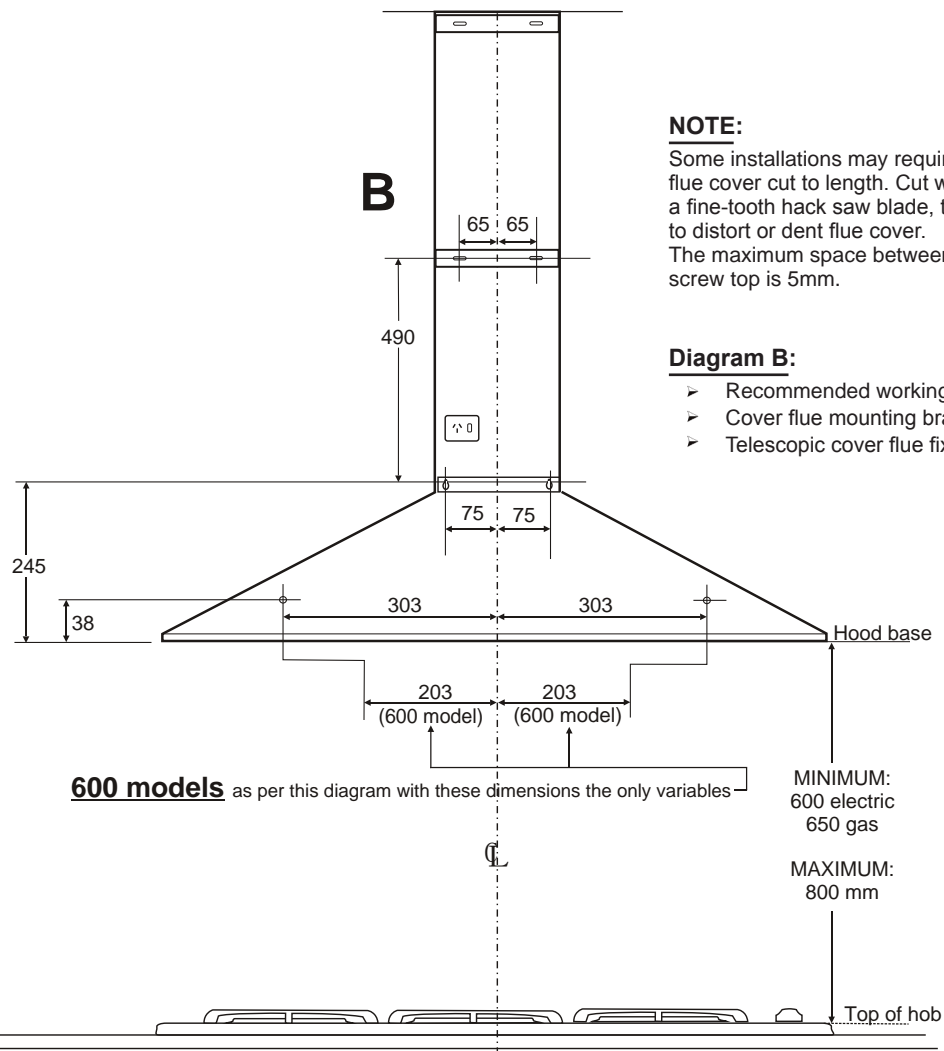

NOTE:

Some installations may require telescopic flue cover cut to length. Cut with tin snips or a fine-tooth hack saw blade, taking care not to distort or dent flue cover. The maximum space between the wall and screw top is 5mm.

Diagram B:

- Recommended working heights.
- Cover flue mounting bracket locations.
- Telescopic cover flue fixing points.

NOTE:

If the instructions of the hob specify a greater distance than the minimum, then that shall be the minimum height for the installation

600 models as per this diagram with these dimensions the only variables

MINIMUM:
600 electric
650 gas

MAXIMUM:
800 mm

RECOMMENDED INSTALLATION SEQUENCE

Diagram D

Install cooker hood body.
Determine working height, mark wall to suit.
Install cover flue mounting brackets.

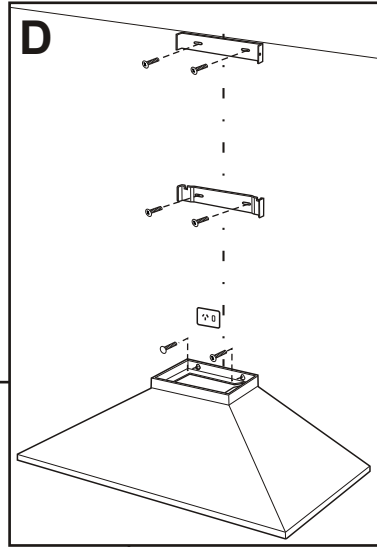
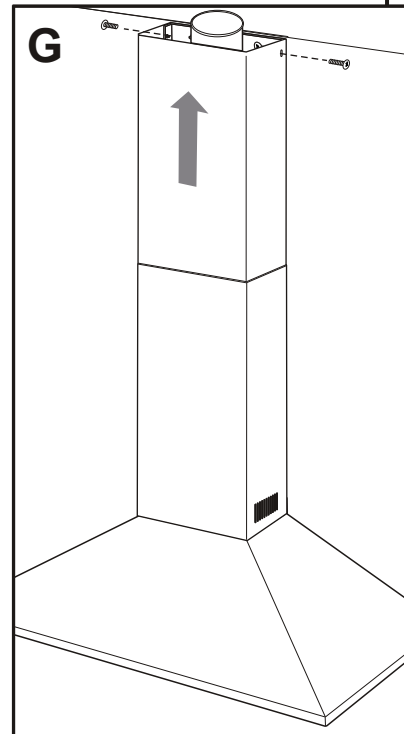
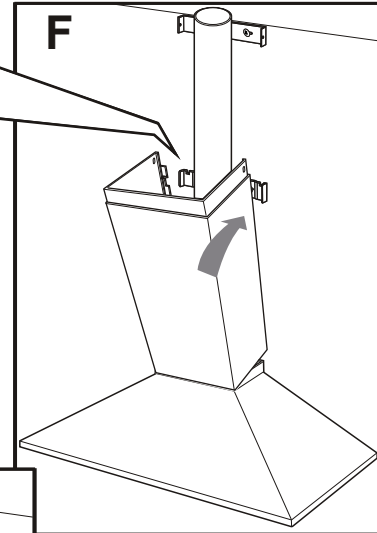
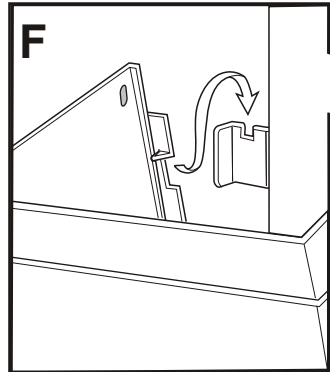
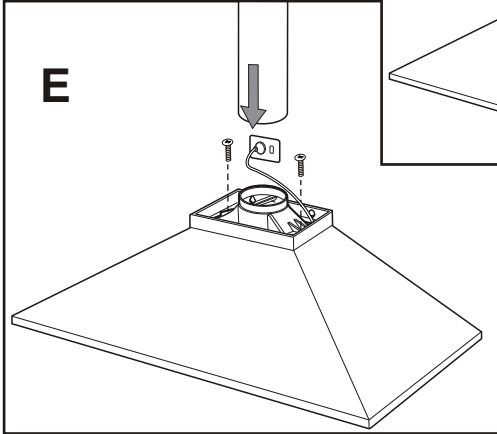

Diagram E

Fix duct transition to cooker hood body.
Install internal exhaust duct to suit installation type.



Diagram(s) F

Install bottom section of telescopic flue cover.

Diagram G

Install top section of telescopic flue cover.

COOKER HOOD OPERATION

IMPORTANT: The Edison Screw lamps may have come loose during transportation. Ensure that lamps are tightened firmly into the socket before power is applied.

Best results are obtained by using a low fan speed for normal conditions and a high fan speed when odours are more concentrated. Turn the hood on a few minutes before you start cooking. It should be left on after cooking for about 15 minutes or until all odours have disappeared.

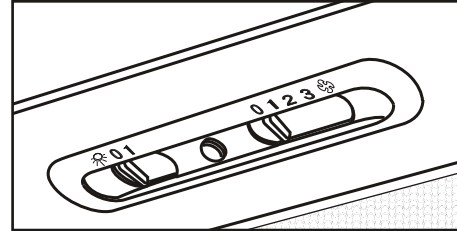

Slide switch controls:

Light switch: ----- This switch is used to turn the light fitted in the hood on and off.
Extractor fan switch: ----- Used to select fan speeds.
Slide position 1: ----- Fan speed Low
Slide position 2: ----- Fan speed Medium
Slide position 3: ----- Fan speed High

Press button switch controls

Light switch: Depress light button to turn light ON. Press light button to turn light OFF.

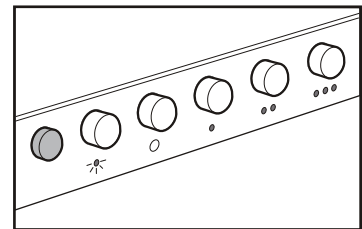

Extractor fan switch interlocked switching:

Select a fan speed, depress button to turn fan ON. Press button (O) to turn fan OFF.

NOTE:

This product is fitted with a safety cutout device. If the cooker hood is installed too close to the cooktop, flame cooking, operating the cooktop without cooking utensils and blocked filters may activate the safety cutout device. If the hood stops during operation, correct the faults and allow time for the safety cutout device to reset, the cooker hood will then function correctly.

Replacing lamps:

Ensure the appliance is switched off before carrying out maintenance, to avoid any possibility of electric shock. Remove grease filter to replace lamp. Replace with 40W (maximum) E14 candle lamp.

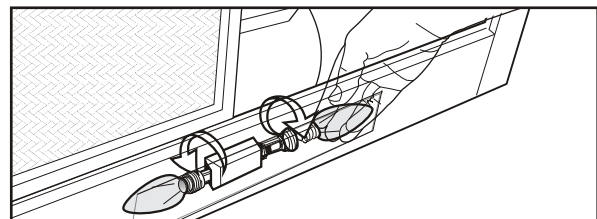

Maintenance:

Clean grease filters every three to four weeks maximum. Greasy filters are a fire risk. Remove the grease filters, soak and agitate in hot soapy water. Rinse, drain and shake well before replacing filters. **Do not** use oven cleaners or other caustic materials.

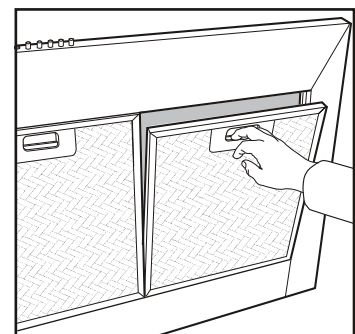

Electrolux Warranty

FOR SALES IN AUSTRALIA AND NEW ZEALAND
APPLIANCE: RANGEHOOD

This document sets out the terms and conditions of the product warranties for Electrolux Appliances. It is an important document. Please keep it with your proof of purchase documents in a safe place for future reference should you require service for your Appliance.

1. In this warranty
 - (a) 'acceptable quality' as referred to in clause 10 of this warranty has the same meaning referred to in the ACL;
 - (b) 'ACL' means Trade Practices Amendment (Australian Consumer Law) Act (No.2) 2010;
 - (c) 'Appliance' means any Electrolux product purchased by you accompanied by this document;
 - (d) 'ASC' means Electrolux' authorised serviced centres;
 - (e) 'Electrolux' means Electrolux Home Products Pty Ltd of 163 O'Riordan Street, Mascot, NSW 2020, ABN 51 004 762 341 in respect of Appliances purchased in Australia and Electrolux (NZ) Limited of 3-5 Niall Burgess Road, Mount Wellington, in respect of Appliances purchased in New Zealand;
 - (f) 'major failure' as referred to in clause 10 of this warranty has the same meaning referred to in the ACL and includes a situation when an Appliance cannot be repaired or it is uneconomic for Electrolux, at its discretion, to repair an Appliance during the Warranty Period;
 - (g) 'Warranty Period' means:
 - (i) where the Appliance is used for personal, domestic or household use (i.e. normal single family use) as set out in the instruction manual, the Appliance is warranted against manufacturing defects in Australia for 24 months and in New Zealand for 24 months, following the date of original purchase of the Appliance;
 - (ii) where the Appliance is used for commercial purposes (including being used to directly assist a business or where the Appliance is used in a multi-family communal or share type environment), the Appliance will then be warranted against manufacturing defects in Australia for 3 months and in New Zealand for 3 months, following the date of original purchase of the Appliance.
 - (h) 'you' means the purchaser of the Appliance not having purchased the Appliance for re-sale, and 'your' has a corresponding meaning.
2. This warranty only applies to Appliances purchased and used in Australia or New Zealand and is in addition to (and does not exclude, restrict, or modify in any way) any non-excludable statutory warranties in Australia or New Zealand.
3. During the Warranty Period Electrolux or its ASC will, at no extra charge if your Appliance is readily accessible for service, without special equipment and subject to these terms and conditions, repair or replace any parts which it considers to be defective. Electrolux or its ASC may use remanufactured parts to repair your Appliance. You agree that any replaced Appliances or parts become the property of Electrolux. This warranty does not apply to light globes, batteries, filters or similar perishable parts.
4. Parts and Appliances not supplied by Electrolux are not covered by this warranty.
5. You will bear the cost of transportation, travel and delivery of the Appliance to and from Electrolux or its ASC. If you reside outside of the service area, you will bear the cost of:
 - (a) travel of an authorised representative;
 - (b) transportation and delivery of the Appliance to and from Electrolux or its ASC,

In all instances, unless the Appliance is transported by Electrolux or an Electrolux authorised representative, the Appliance is transported at the owner's cost and risk while in transit to and from Electrolux or its ASC.

6. Proof of purchase is required before you can make a claim under this warranty.
7. You may not make a claim under this warranty unless the defect claimed is due to faulty or defective parts or workmanship. Electrolux is not liable in the following situations (which are not exhaustive):
 - (a) the Appliance is damaged by:
 - (i) accident
 - (ii) misuse or abuse, including failure to properly maintain or service
 - (iii) normal wear and tear
 - (iv) power surges, electrical storm damage or incorrect power supply
 - (v) incomplete or improper installation
 - (vi) incorrect, improper or inappropriate operation
 - (vii) insect or vermin infestation
 - (viii) failure to comply with any additional instructions supplied with the Appliance;
 - (b) the Appliance is modified without authority from Electrolux in writing;
 - (c) the Appliance's serial number or warranty seal has been removed or defaced;
 - (d) the Appliance was serviced or repaired by anyone other than Electrolux, an authorised repairer or ASC.
8. This warranty, the contract to which it relates and the relationship between you and Electrolux are governed by the law applicable where the Appliance was purchased. Where the Appliance was purchased in New Zealand for business purposes the Consumer Guarantee Act does not apply.
9. To the extent permitted by law, Electrolux excludes all warranties and liabilities (other than as contained in this document) including liability for any loss or damage whether direct or indirect arising from your purchase, use or non use of the Appliance.
10. For Appliances and services provided by Electrolux in Australia, the Appliances come with a guarantee by Electrolux that cannot be excluded under the Australian Consumer Law. You are entitled to a replacement or refund for a major failure and for compensation for any other reasonably foreseeable loss or damage. You are also entitled to have the Appliance repaired or replaced if the Appliance fails to be of acceptable quality and the failure does not amount to a major failure. The benefits to you given by this warranty are in addition to your other rights and remedies under a law in relation to the Appliances or services to which the warranty relates.
11. At all times during the Warranty Period, Electrolux shall, at its discretion, determine whether repair, replacement or refund will apply if an Appliance has a valid warranty claim applicable to it.
12. For Appliances and services provided by Electrolux in New Zealand, the Appliances come with a guarantee by Electrolux pursuant to the provisions of the Consumer Guarantees Act, the Sale of Goods Act and the Fair Trading Act.
13. To enquire about claiming under this warranty, please follow these steps:
 - (a) carefully check the operating instructions, user manual and the terms of this warranty;
 - (b) have the model and serial number of the Appliance available;
 - (c) have the proof of purchase (eg an invoice) available;
 - (d) telephone the numbers shown below.
14. You accept that if you make a warranty claim, Electrolux and its ASC may exchange information in relation to you to enable Electrolux to meet its obligations under this warranty.

Important Notice

Before calling for service, please ensure that the steps listed in point 13 above have been followed.

<p>FOR SERVICE or to find the address of your nearest state service centre in Australia PLEASE CALL 13 13 49 For the cost of a local call (Australia only)</p>	<p>SERVICE AUSTRALIA  ELECTROLUX HOME PRODUCTS www.electrolux.com.au</p>	<p>FOR SPARE PARTS or to find the address of your nearest state spare parts centre in Australia PLEASE CALL 13 13 50 For the cost of a local call (Australia only)</p>
<p>FOR SERVICE or to find the address of your nearest authorised service centre in New Zealand FREE CALL 0800 10 66 10 (New Zealand only)</p>	<p>SERVICE NEW ZEALAND  ELECTROLUX HOME PRODUCTS www.electrolux.co.nz</p>	<p>FOR SPARE PARTS or to find the address of your nearest state spare parts centre in New Zealand FREE CALL 0800 10 66 20 (New Zealand only)</p>

GRH_Warr_Apr11