

INSTRUCTIONS

When correctly installed, your refrigerator should:

- Have adequate clearance to the back, sides and top for air circulation
- Be aligned to the surrounding cupboards
- Have doors that will self close from a partially open position

CLEARANCES AROUND YOUR REFRIGERATOR

Your Side by Side refrigerator can be installed between cupboards or fixtures but you must allow for the following spaces around the cabinet.

- Allow a minimum of 5mm clearance on both sides (see diagram 1)
- Allow a minimum of 10mm clearance above hinge covers (see diagram 1)
- Allow 10mm clearance at the back of the refrigerator (see diagram 1)

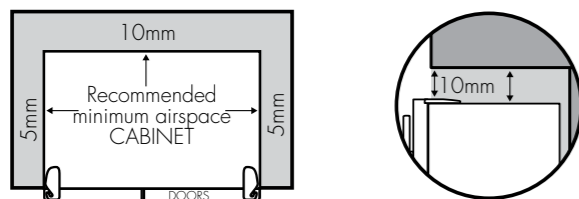

Diagram 1

- If you place the refrigerator next to a wall, allow a minimum clearance of 250mm for freezer side and 350mm for fridge side of the doors, this will allow easy removal of shelves and bins for cleaning (refer to diagram 2).
- The refrigerator is designed to sit proud of cupboards and other fixtures. To enable doors to open fully, ensure that other fixtures do not stick out further than the refrigerator cabinet (see diagram 2).

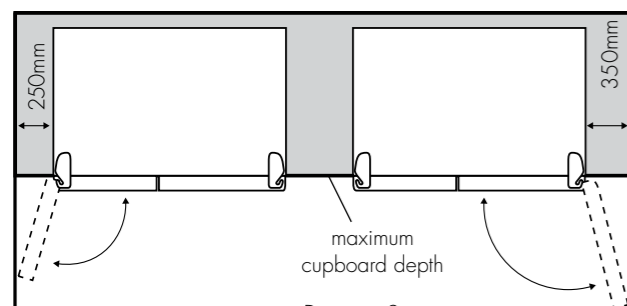
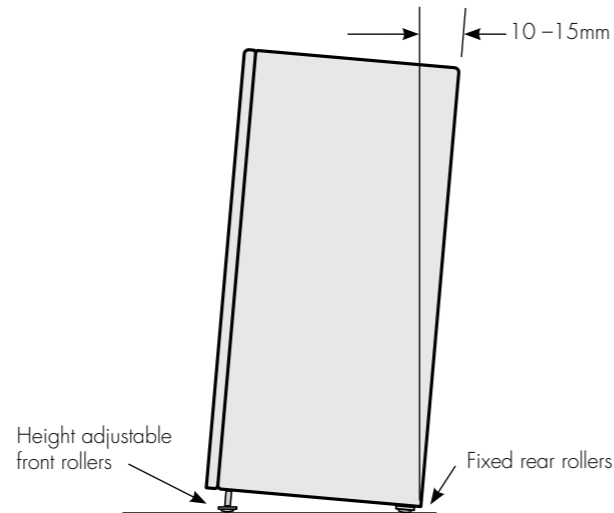

Diagram 2

INSTALLATION

The refrigerator should arrive with the front rollers wound down. We recommend that the appliance be tilted backwards by about 10mm to 15mm, this will allow the doors to self close providing a consistent door seal. To do this follow the instructions below.



When you want to install your appliance, take the following steps.

1. Roll the refrigerator into it's final position.

**WARNING**

The rollers are designed for forward or backward movement only. They are not castors. Moving the refrigerator sideways may damage your floor and the rollers.

2. If the refrigerator is not tilted back you can adjust the two front rollers by adjusting the large plastic roller nut. You may need two people, one to adjust rollers and one to tilt the refrigerator slightly back to take the weight of the appliance off the front rollers. This will increase or decrease the height of the rollers. One turn of the nut will change the tilt of the refrigerator by approximately 5mm.
3. If the cabinet is level, then the side walls should be plumb or vertical. If the cabinet is built in or partly built in check the alignment of the cabinet side against the cupboard.

INSTRUCTIONS

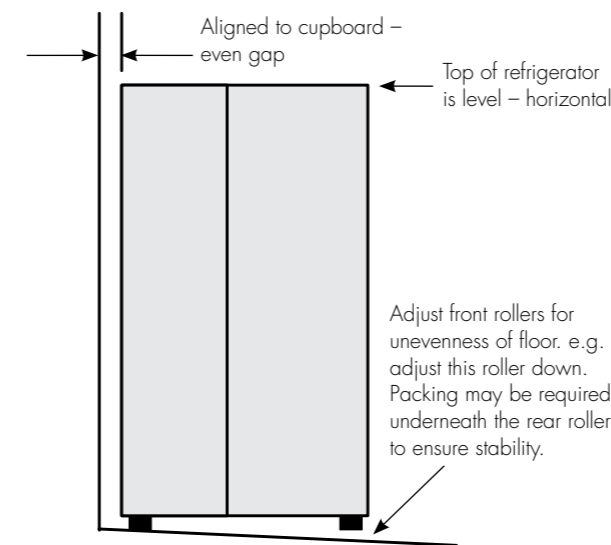

4. If the appliance now rocks from one corner to the opposite rear corner, this means that the floor is uneven; you will need to put some packing under one of the rear rollers.
5. You may now need to fine-tune the installation by adjusting the front rollers once again.

ADJUSTING DOOR ALIGNMENT

Each door is independently adjustable in the vertical direction by turning the adjustable bolts under the hinges using the spanner provided.

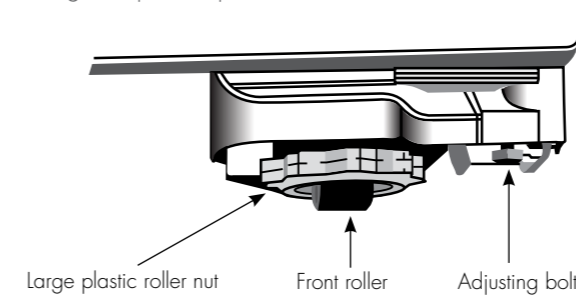

The doors can be adjusted up or down. Depending on the amount of adjustment required it may be sufficient to adjust only one door (refer to following diagrams).

*NOTE: When the height of the rollers and adjusting bolts are correctly adjusted the refrigerator will stand firmly on the floor and the doors will be in line with one another.*

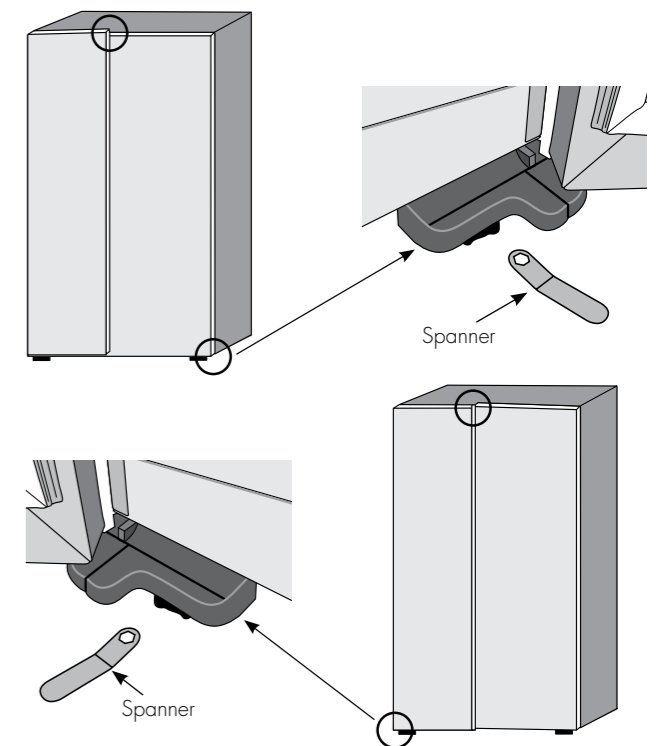

INTERNAL PACKAGING

1. Please remove all internal packaging material before use. Any glue or tape residue or the like should be removed with a solution of mild detergent and water.
2. Clean your appliance thoroughly and wipe off any dust that has accumulated during shipping.
3. It is recommended that the refrigerator is kept upright at all times. However if for any reason the refrigerator is laid down, let it stand for a minimum of 1 hour before turning on.

**WARNING**

Before cleaning: Remove the power cord from the power socket. This will make sure there is no chance of getting an electric shock.

4. Install accessories such as the egg tray. The accessories are packed together to prevent damage during delivery.
5. Plug your appliance into the power point.
6. We recommend that you let your refrigerator run for two to three hours before you put any food in it. This will allow you to check that it is operating properly and that enough cool air is circulating.

Remove this sticker with **care!** Installation instructions are printed on the back.

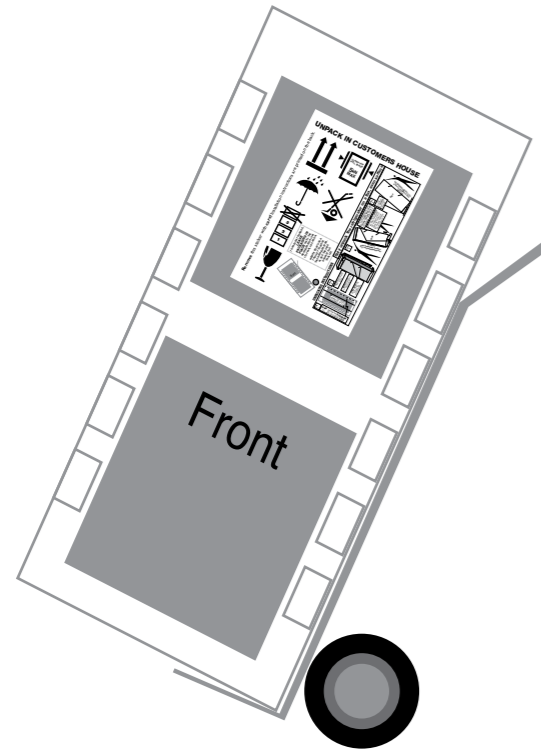
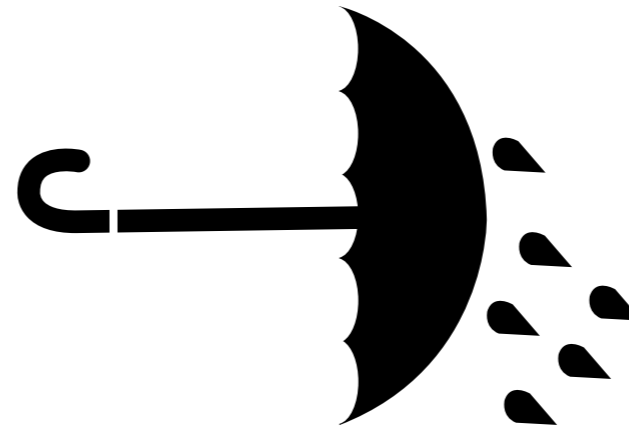
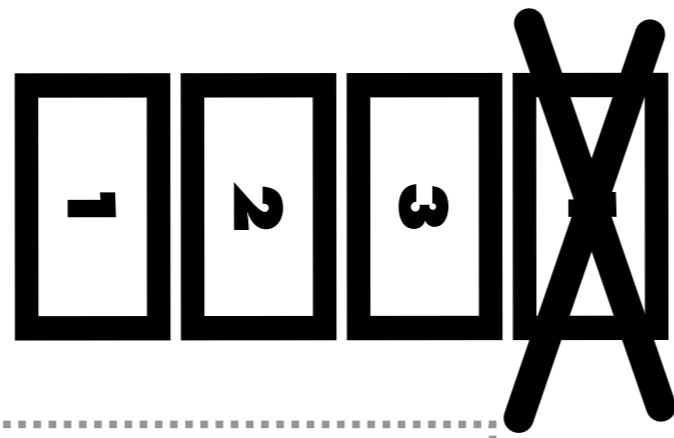
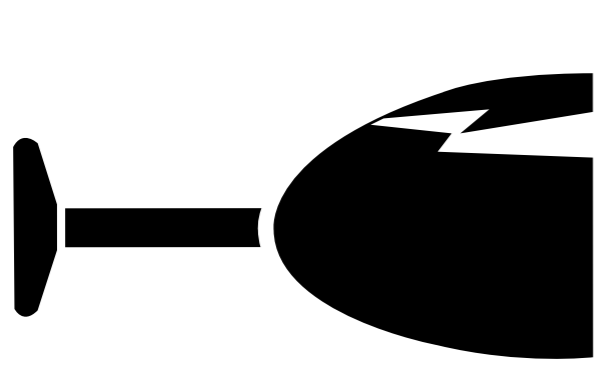

TO PREVENT DAMAGE,  
**LEAVE PACKAGING IN PLACE** UNTIL THE REFRIGERATOR IS IN ITS FINAL LOCATION.

**HEAVY! ITEM! USE A TROLLEY TO MOVE THIS REFRIGERATOR. PLACE THE SIDE AGAINST THE TROLLEY.**

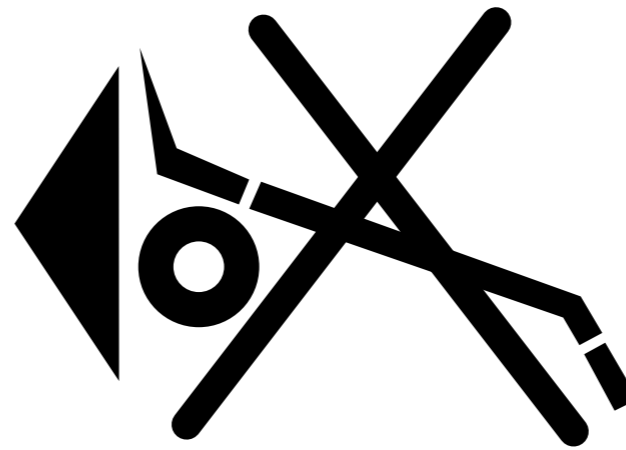

## UNPACKING INSTRUCTIONS

**Only unpack the refrigerator on a flat, even surface!**

**Step 1**  
CUT SIDES & TOP TO REMOVE PLASTIC BAG  
CUT STRAP

**Step 2**  
REMOVE PACKAGING FROM THE TOP AND SIDES  
INSPECT YOUR PRODUCT FOR DENTS OR DAMAGE  
LEAVE TAPES ON WHILE TILTING OR MOVING THE REFRIGERATOR

**Step 3**  
TILT REFRIGERATOR AND SLIDE THE **RECTANGULAR PACKING BLOCK** BEHIND PACK BASE CENTRE LINE.  
STEP DOWN TO **BREAK** PACKING BASE AND KICK SIDWAYS TO REMOVE FRONT OF PACK BASE. REMOVE PACKING BLOCK  
TILT THE REFRIGERATOR!  
BE SAFE!  
ASK SOMEONE TO HELP!

**Step 4**  
TILT FORWARD TO REMOVE REAR PART OF BASE  
TILT THE REFRIGERATOR!  
BE SAFE!  
ASK SOMEONE TO HELP!

**UNPACK IN CUSTOMERS HOUSE**