



Assembly and Operating Instructions

CLUBMAN

FOR MODELS:

16440, 16540, 16640, 16740

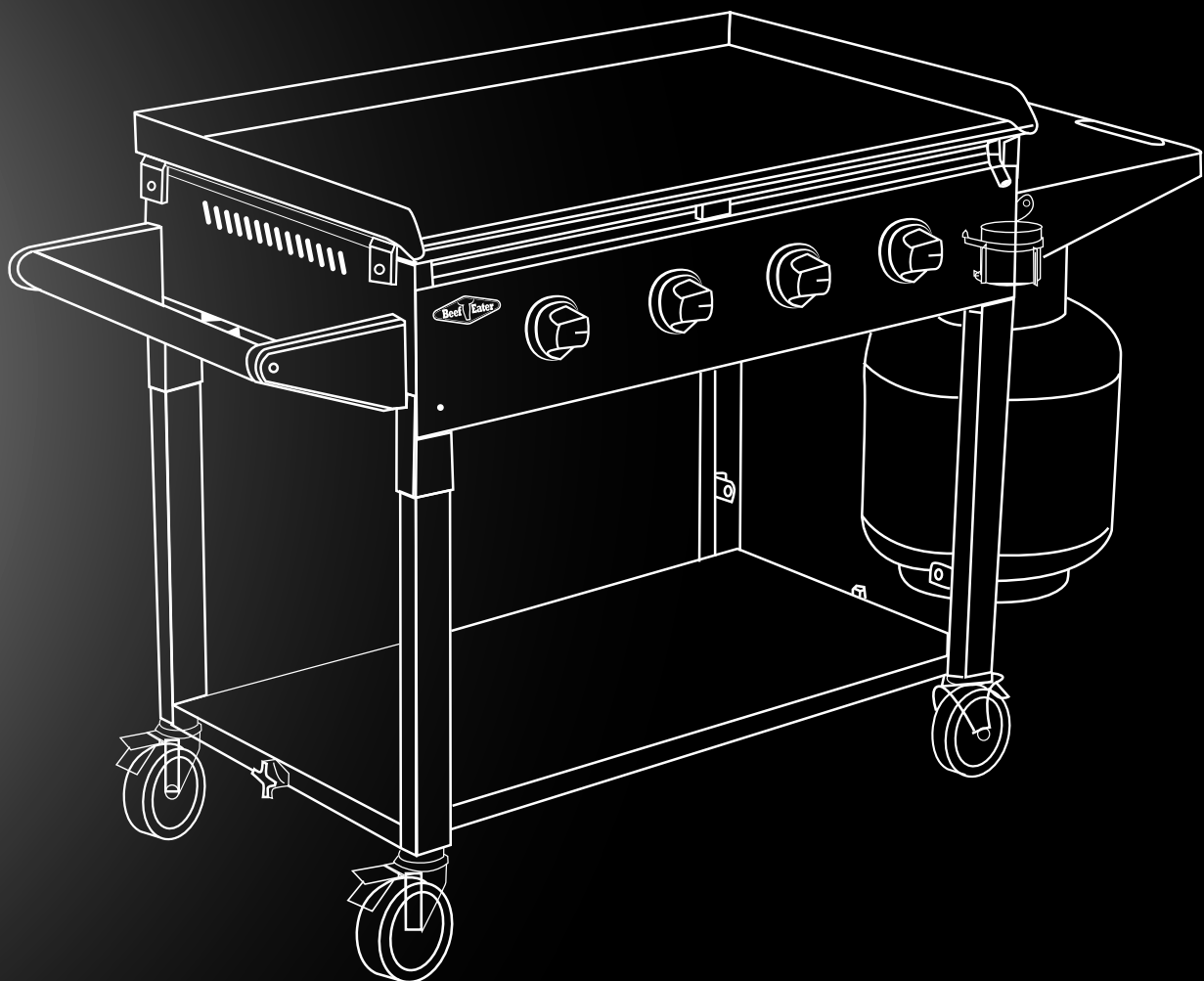

FOR OUTDOOR USE ONLY

AUSTRALIA / NEW ZEALAND

Dear customer,

Congratulations and thank you for choosing our barbecue. We are sure you will find it a pleasure to use. Before you use the barbecue, we recommend that you read through the relevant sections of this manual, which provide a description of your appliance and its functions.

To avoid the risks that are always present when you use an appliance, it is important that the appliance is installed correctly and that you read the safety instructions carefully to avoid misuse and hazards.

We recommend that you keep this instruction booklet for future reference and pass it on to any future owners.

After unpacking the appliance, please check it is not damaged. If in doubt, do not use the appliance but contact your local customer care centre.

This appliance complies with requirements of Australian Standards AS4557.

Conditions of use

These important notes apply to your appliance, failure to adhere to these conditions of use may affect your ability to make a claim under the manufacture's warranty.

- This appliance must be serviced only by a qualified licenced person.
- This product is intended for personal, domestic or household use only, not commercial use.
- This product is intended for outdoor use only.
- This product must be installed, operated and maintained as per the instructions.
- Ventilation holes in the unit must not be obscured by the installation.

Please ensure you read the instruction manual fully before you call for service, or a full service fee could be applicable.

Record model and serial number here:

Model number:

Serial number:.....

PNC:.....

Important safety instructions.....	3
Gas specifications.....	4
Know your clubman barbecue.....	5
Installation instructions.....	6
Using your barbecue.....	10
Partial enclosures.....	11
Technical information.....	11
Maintenance.....	12
Maintenance troubleshooting.....	13
Notes.....	14
Warranty.....	15

Please read the user manual carefully and store in a handy place for later reference.

The symbols you will see in this booklet have these meanings:



WARNING

This symbol indicates information concerning your personal safety.



CAUTION

This symbol indicates information on how to avoid damaging the appliance.



IMPORTANT

This symbol indicates tips and information about use of the appliance.



ENVIRONMENT

This symbol indicates tips and information about economical and ecological use of the appliance.

Please read the user manual carefully and store in a handy place for later reference.



IMPORTANT

Important – check for any damages or marks

If you find the barbecue is damaged or marked, you must report it within 7 days if you wish to claim for damage/marks under the manufacturer's warranty. This does not affect your statutory rights.



ENVIRONMENT

Information on disposal for users

- Most of the packing materials are recyclable. Please dispose of those materials through your local recycling depot or by placing them in appropriate collection containers.
- If you wish to discard this product, please contact your local authorities and ask for the correct method of disposal.



WARNING

This appliance must be serviced only by a qualified licensed person.

Improper installation, adjustment, alteration or maintenance can cause injury or property damage and may affect your ability to claim under the manufacturer's warranty.

Please contact your nearest BeefEater Service Department for additional information or assistance for an approved installer.

Note to the installer

This manual must remain with the owner for future reference.



WARNING

- Do not lean over barbecue when lighting.
- Do not leave the barbecue unattended when alight.
- Do not delay lighting once the gas has been turned on.
- Do not store or use aerosol cans in the vicinity of the barbecue.
- Do not store flammable liquids in the vicinity of the barbecue.
- Do not use caustic or abrasive based cleaners on the barbecue.
- Do not attempt to dismantle or adjust the control valves.
- Do not attempt to dismantle or adjust the regulator.
- Do not test for leaks with a naked flame.
- Do not modify the construction of this appliance or modify the injector orifice size.
- Do not obstruct any ventilation of the barbecue.
- Do not allow children to operate or play near the barbecue.

Failure to adhere to the above warnings may cause injury or property damage and affect your ability to make a claim under the manufacturer's warranty.



CAUTION

This appliance is set up for Universal LPG and is labelled accordingly. A natural gas conversion kit is available if required. Conversion of this unit to natural gas must be carried out by a qualified licensed person and a Certificate of Compliance must be issued to the owner at the completion of the installation and conversion.

Where a mobile appliance is to be connected to a fixed gas supply via a flexible hose connection, a retaining tether of adequate strength shall be fixed to the appliance and be suitable to be fixed to the wall within 50mm of each connection point. The length of the tether shall not exceed 80% of the length of the hose assembly. In this way, if the barbecue is accidentally moved, the chain stops the barbecue from stretching the hose.

The barbecue appliance must be isolated from the gas supply piping system by closing its manual shutoff valve during any pressure testing of the gas supply piping system.



IMPORTANT

BeefEater barbecues are approved for OUTDOOR USE ONLY and must not be used in a building, garage or any other enclosed area.

- BeefEater barbecues must not be used inside recreational vehicles or boats.
- Read instructions thoroughly before operating this barbecue.
- Save this manual for future reference.
- Always use the barbecue on a flat, level surface.
- Some foods produce flammable fats and juices. Regular cleaning is essential.
- Attend an operating barbecue at all times. Damage caused by fat & grease fires is not covered by warranty.
- When not in use keep barbecue dry and covered.



WARNING

If you smell gas

1. Shut off gas to the appliance.
2. Extinguish any open flame.
3. Open hood.
4. If odour continues, immediately call your gas supplier or your fire department.

For your safety

1. Do not store or use gasoline or other flammable vapours or liquids in the vicinity of this or any other appliance.
2. An LPG cylinder not connected for use shall not be stored in the vicinity of this or any other appliance.

GAS SPECIFICATIONS

WARNING

- Gas cylinders must be stored outdoors, out of reach of children and must not be stored in a building, garage or any other enclosed area.
- This appliance is designed to be used with a gas cylinder not exceeding 9KG (20lbs) capacity.
- The Gas cylinder must be constructed and marked in accordance with specifications for LP Gas Cylinders.
- The gas cylinder supply valve must be turned off when the appliance is not in use.
- The gas cylinder used must incorporate a safety collar to protect the valve assembly.
- The gas cylinder must always be kept and used in the upright position.
- Gas cylinder must be positioned on the dedicated cylinder hook when in use.

IMPORTANT

When disconnecting and removing the gas cylinder for the purpose of refilling, always observe the following procedure:

- Ensure that all gas control valves on the appliance and the gas cylinder are turned off before disconnecting the gas line from the cylinder.
- Do not smoke or use a naked flame near the appliance or gas cylinder while disconnecting the gas line between the appliance and gas cylinder.
- Remove the gas cylinder from the enclosure before disconnecting the gas line from the appliance.
- Tighten all connections before placing the gas cylinder back in its enclosure.

The Gas Leak Testing Procedure should be conducted every time the gas cylinder is refilled and reconnected to the appliance – before using the appliance.

Regulator Connection

1. Check that all control knobs are in the 'Off' position.
2. Make sure the cylinder valve is off by turning the valve knob all the way clockwise.
3. Remove the protective cap from the cylinder if present.
4. Make connection as described in figures 1 and 2.
5. Leak-test the connection with a soapy water solution. (See Gas Leak Testing Procedure). Hose and regulator replacement must be a genuine part specified for this appliance and is obtainable from your nearest BeefEater stockist.

FIG 1
Standard POL regulator (AU/NZ regulator)

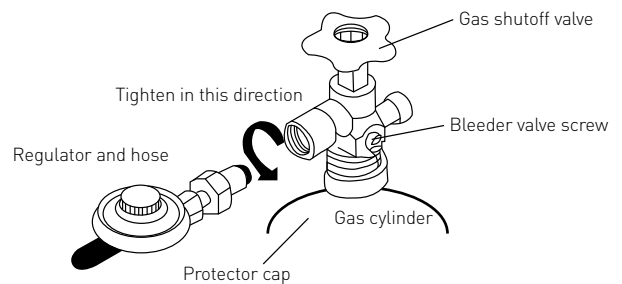
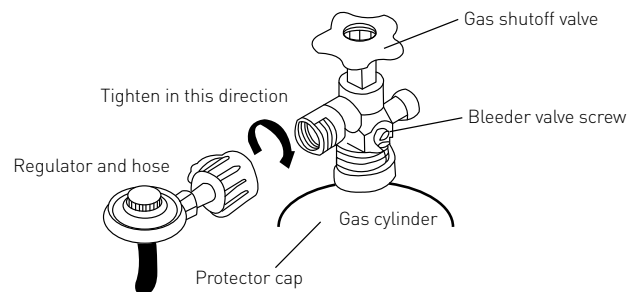

FIG 2
Quick connect regulator (North America regulator)



Gas Leak Test Procedure

Use the following procedure to check for gas leaks. Never use a naked flame to check for gas leaks.

1. In a small container, mix up a solution of water and detergent or soap. Mix the solution well.
2. Make sure that the gas supply valve on the gas cylinder is turned on.
3. Make sure that the gas control valves on the appliance are all turned off.
4. Using a brush or spray bottle apply the solution to the gas line and each join in the gas line. See Fig 3.
5. Bubbling of the solution will indicate that there is a leak present.
6. Re-tighten or re-seal any joints that are leaking.
7. If a leak persists then contact your distributor or the manufacturer for assistance.

FIG 3

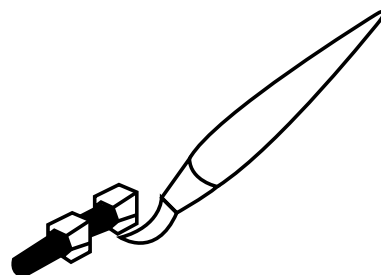



- ① RH Side wheels Frame
- ② Folding shelves
- ③ LH Side Wheels Frame
- ④ Thumb screws
- ⑤ Cooking Plate
- ⑥ Operating Knobs
- ⑦ Handle
- ⑧ Bottom Shelf or Cross Brace
- ⑨ Fat Collecting Cup
- ⑩ Cylinder Hook (under RH shelf)

INSTALLATION INSTRUCTIONS

The legs are folded on the underside of the BBQ. To unfold:

1. Place the BBQ upside down, and release legs by unscrewing the 2 Hand Screws.

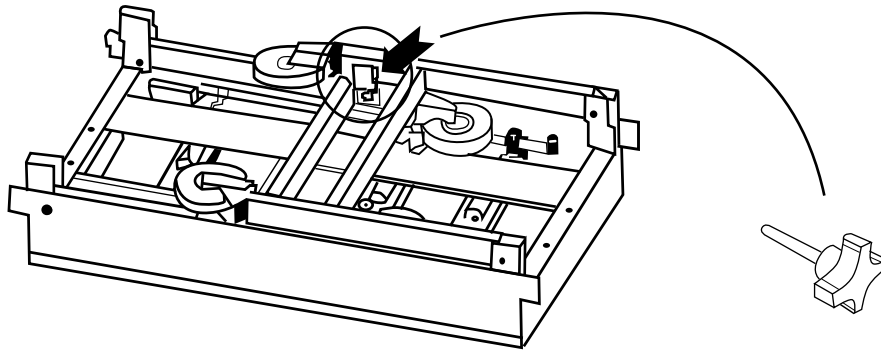

2. Pull both Wheels Frames to a vertical position. Place the bottom shelf (or cross-brace) in between the horizontal members, and tighten with a hand-screw on each side.

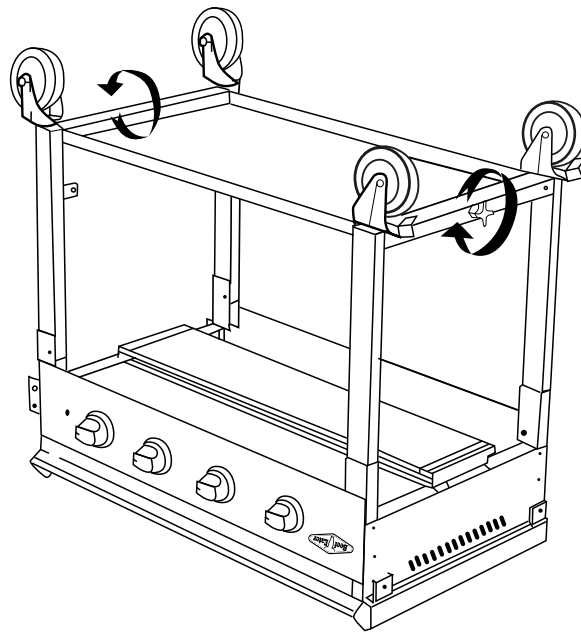

3. Turn back the right way, and install the fat collecting cup holder. Place cup inside.

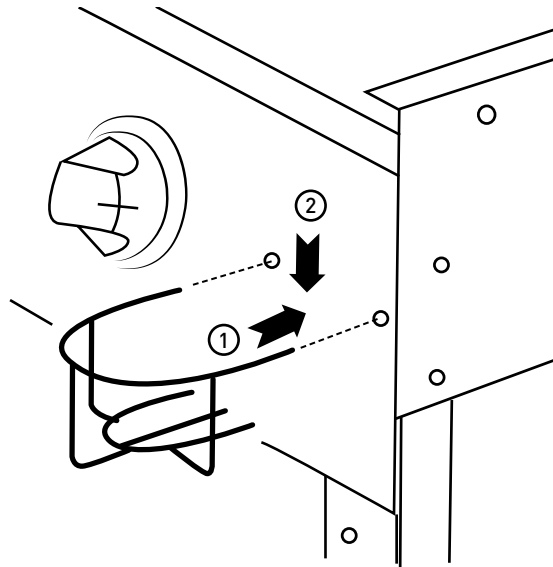

4. Install the shelf on the right hand side. [Clubman Only. Clubmate has handles on both sides]:
The shelf should be installed such that the bottom screw in each bracket will go through the hole in the shelf. The top remain free, so the shelf can be folded.

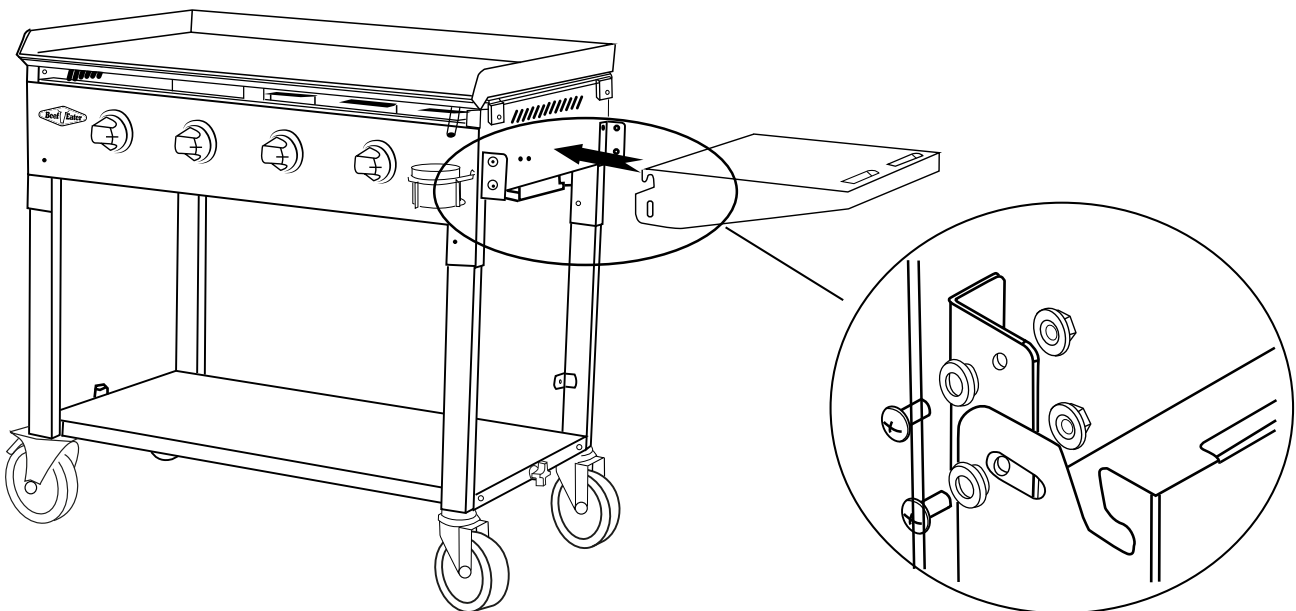

INSTALLATION INSTRUCTIONS

5. Install cylinder hook over the 2 studs under the right-hand side shelf.

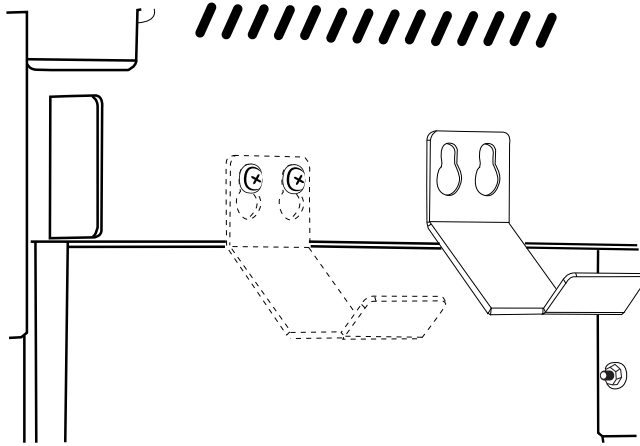

6. Fit the handle on left hand side:

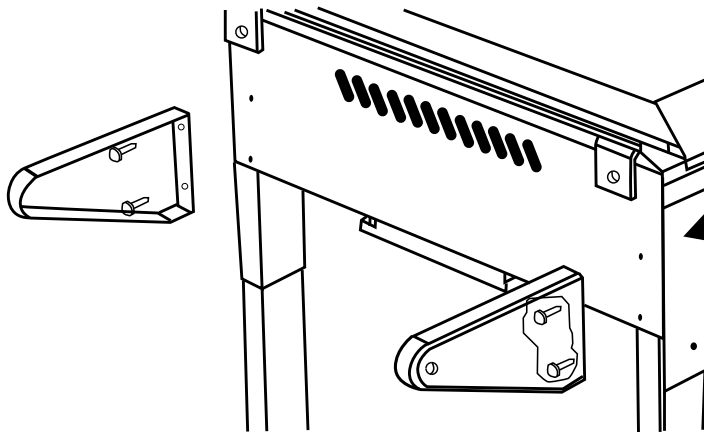

a

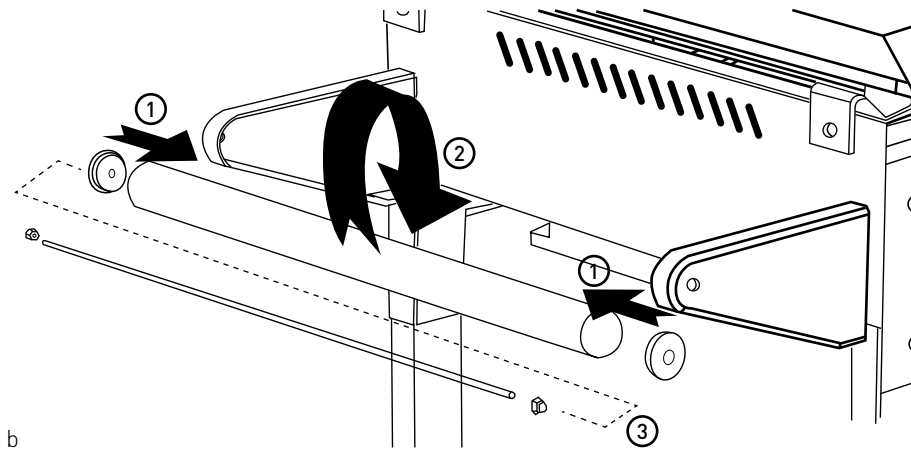

1. Assemble the black spacers to the ends of the handle tube.
2. Insert the assembled tube in between the brackets.
3. Insert threaded rod through brackets and handle, and tighten with a nut on each side.

The Cooking Plate of this BBQ is designed so it can be removed for easier transportation of the appliance. To remove the plate, you must undo the 5 thumb screws holding it to the body. Two at each side, and one at rear.



Note: when operating the BBQ, it must be ensured that all 5 Thumbscrews holding the plate are in place and fastened tightly.

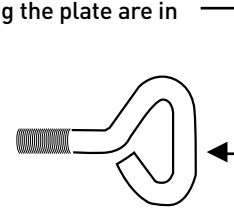

Connect the Regulator to the gas Cylinder



WARNING

Verify 'Gas Type' label & data plate attached to side of barbecue is correct for the gas you are about to connect to.

The hose and regulator is connected to the BBQ and leak tested at factory, you will only need to connect to the cylinder, as explained on page 4.

1. Make sure burner valves are in the 'Off' position.
2. Screw regulator side to the cylinder, and hand-tighten.



CAUTION

Note: if moving the BBQ from one place to another, never drag the cylinder behind. Disconnect the cylinder first, move, and re-connect once reached the new location.



WARNING

Note: For storage and cylinder exchange, disconnect hose at the cylinder only, do not disconnect hose from the appliance.

Once finished using the barbecue

1. Disassembly operation must be done after the barbecue has totally cooled off.
2. Be careful when removing fat collecting cup, because the grease in the cup may take longer to cool down.
3. When transporting the barbecue, make sure that all parts are locked firmly to place.



WARNING

Note: for 16540, 16640 and 16740 barbecues, the plate is made of Mild Steel, and coated with non-toxic paint to protect it from rusting. With use, the coating may come off, and while posing no hazard, it is recommended to keep the plate lightly oiled while not in use, and keep the barbecue covered, to prevent corrosion of the plate.

USING YOUR BARBECUE

Ignition:

Model **16440** and **16640** does not require a battery and has a QuartzStart ignition system built into every valve.

For **16540** and **16740** models, A battery must be inserted into the ignition module in order for it to work.

Unscrew the top of the ignition button (holding onto the knurled, rigid part), and insert 1 x AA battery, such that the positive (+) side is towards you. Replace cup.

Preparing the Plate:

To protect the steel cooking surface during transport and prior to purchase, a non-permanent and non-toxic coating is applied. This coating will wear off in time with use. To help preserve the cooking surfaces and to minimise corrosion and sticking, cooking plate is best seasoned before use.

Wash the plate thoroughly with mild dishwashing liquid and dry immediately. Do not allow to drain-dry. Coat top surface with a generous layer of solid vegetable oil. Do not use salted fats such as butter or margarine.

With barbecue plate placed in the correct position, light the burners according to this instruction manual. Turn the burners on to the High setting until a medium heat is attained. After about 10 minutes turn all burners Off and allow the unit to cool completely. Coat again with vegetable oil. The cooking plate is now seasoned and ready to use. The cooking surface should be frequently seasoned as above to prevent corrosion. If rust does occur, clean with a wire brush and repeat the seasoning process. In a marine environment more frequent seasoning may be required.

To Turn Off a Burner

Push in and hold the control knob while turning in a clockwise direction until the 'Off' position is reached. Failure to follow these shutdown/turnoff procedures exactly could lead to a hazardous situation.

Cooking Method

Commonly used for traditional barbecuing:

Place food over the lit plate section. Observe cooking process and turn food over as required to achieve uniform cooking.

The direct cooking method is recommended for steaks, chops, sausages, and hamburgers, as well as vegetables.

To Operate

- A. The appliance is placed on a flat, level, non-combustible surface.
- B. Ensure the regulator is connected to the LPG cylinder (See Regulator Connection page 4.), and the hose is not subject to any twisting.
- C. Verify all joints are spanner tight and check for leaks after turning on gas supply. See correct procedure on page 4.
- D. Ensure all knobs are in the 'Off' position.
- E. Ensure cooking plate is in place, and secured with all Thumb screws.
- F. Open Gas Cylinder valve.
- G. Light each burner by following this procedure (16540 and 16740):
 - Read all instructions before lighting.
 - Before lighting ensure plate is secured.
 - Push in and turn Left-Hand-Side knob counter clockwise to 'High', while pressing the Ignition button (a 'Clicking' sound will be heard).
 - If ignition does not occur, return to 'Off' and repeat after 5 minutes.
- H. Once the left-hand-side burner is alight, light each successive burner from left to right. or
- I. Light each burner by following this procedure (16440 and 16640):
 - Read all instructions before lighting.
 - Before lighting ensure plate is secured.
 - Push in and turn any knob counter-clockwise towards 'High'.
 - If ignition does not occur, return to 'Off' and repeat after 5 minutes.
- J. Check for a clear blue flame with just a tip of yellow.



WARNING

Excess yellow tipping means the combustion is not right, if that is observed, turn the barbecue burners off, and refer to troubleshooting at the end of this manual.

Controlling the Burners

The control knob can now be turned to the desired heat setting, Low, Medium or High. The control knob does not need to be pushed in while selecting the heat setting.

After Use

It is a good idea to leave the barbecue 'On' for about 10 minutes after you have finished cooking. This helps to burn away any excess food residues and oil, and makes cleaning easier.

- Be sure to turn off all control knobs and the gas supply.
- Allow the barbecue to cool.
- Clean the fat collecting cup and cooking surfaces. Clean any food spills from the side shelves, if they are installed.
- The gas cylinder supply valve must be turned off when the appliance is not in use.

Storing Your Barbecue

When storing barbecue for extended periods, be certain all controls and cylinder valves are turned off. If storing the barbecue indoors remove gas cylinder and store the cylinder in a ventilated area outdoors. Gas cylinders must be stored outdoors, out of reach of children and must not be stored in a building, garage or any other enclosed area.

The barbecue should be covered when not in use. Eg with a polyester or vinyl barbecue cover.

This appliance shall only be operated in an above ground, open air situation with natural ventilation, without stagnant areas, where gas leakage and products of combustion are rapidly dispersed by wind and natural convection. Failure to adhere to these installation instructions may cause injury or property damage and affect your ability to make a claim under the manufacturer’s warranty. Any enclosure in which the appliance is used shall comply with one of the following:

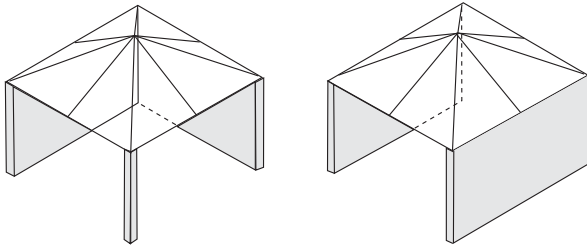

Within a partial enclosure that includes an overhead cover and no more than two walls.

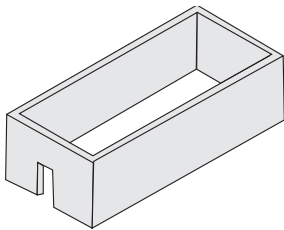

Any enclosure with walls on all sides, but at least one permanent opening at ground level, and no overhead cover.

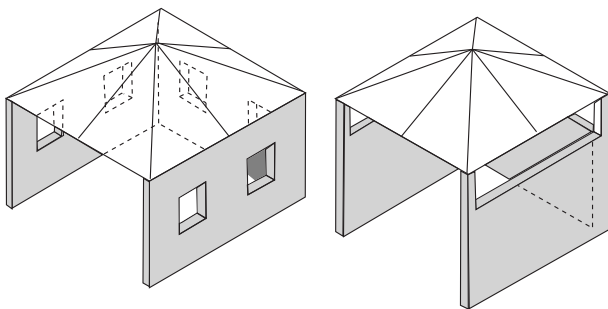

Within a partial enclosure that includes an overhead cover and more than two walls, the following shall apply:

- At least 25% of the total wall area is completely open; and
- At least 30% of the remaining wall area is open and unrestricted.

In the case of balconies, at least 20% of the total of the side, back and front wall areas shall be and remain open and unrestricted.

⚠ WARNING

Note: Do not modify this appliance. Any deviation from factory settings could result in a safety hazard.

Barbecue manifold inlet thread is 3/8 SAE male flare fitting.
 Operation Gas Pressure: LPG – 2.75 Kpa; NG – 1.0 Kpa
 Energy Input: 18Mj per Burner.

Gas Nozzle orifice size: LPG – Ø1.2mm; NG – Ø1.95mm

APPLIANCE	LENGTH [MM]	HEIGHT [MM]	DEPTH [MM]	WEIGHT [KG]
4 Burner ClubMan 16440, 16540, 16640, 16740	920	830	520	67

MAINTENANCE

1. Use only soft cloth or sponge to clean the surfaces of barbecue and then carefully dry.
2. Avoid leaving acidic or alkaline substances on the plate. It may cause discolouration and corrosion.
3. Keep the igniters probes clean. Wipe away any apparent water or dirt.
4. Clean the unit after each use to maintain the appearance and prolong the appliance's life. Do not use corrosive materials or harsh detergents to clean the BBQ.

SERVICE AND MAINTENANCE	EACH USE	6 MONTHLY	EVERY 2 YEARS
Check gas supply hose(s) for cracks and leaks	✓		
Check gas regulator for leaks	✓		
Check that all gas fittings are tight	✓		
Inspect and clean ignition module and probe		✓	
Inspect and clean barbecue burners		✓	
Inspect and clean gas injectors			✓
Check gas control valve on cylinder			✓
Inspect gas control valves			✓
Inspect and proof all internal structure barbecue and trolley			✓

CONDITION	POSSIBLE CAUSE	SOLUTION
Flame goes out while in use	Empty gas cylinder	Replace cylinder
	Air mixed in hoses	Re-ignite and allow operating for a short while, till clears out
	Blockage	Seek professional assistance
Ignition failure	Gas cylinder valve close	Turn off knob button, then open the cylinder valve
	Air mixed in the hoses	Re-ignite and allow operating for a short while, till clears out.
	Rubber hose wrapped, deformed or pinched	Release hose, ensure not damaged or leaking
	Spark escaping	Ensure the spark probe is in place, not deformed, clean.
	No spark	Replace igniter battery Check ignition probe.
Foul smell of gas	Damage to hose	Turn cylinder valve off, replace hose.
	Leakage	Leak-test, and tighten where required. If leakage can't be rectified, cease using appliance, and seek professional assistance
	Burner went off	Shut off valves, wait for 5 minutes and reignite
	Incorrect combustion	Seek professional assistance
Flame appears to separate off the burner or flame burns with noise	Blockage of burner pots	Clean the burner thoroughly. If problem persists, Seek professional assistance



Electrolux Warranty

FOR SALES IN AUSTRALIA AND NEW ZEALAND
APPLIANCE: BEEFEATER DISCOVERY BBQ

This document sets out the terms and conditions of the product warranties for BeefEater Appliances. It is an important document. Please keep it with your proof of purchase documents in a safe place for future reference should there be a manufacturing defect in your Appliance. This warranty is in addition to other rights you may have under the Australian Consumer Law.

1. In this warranty:

- (a) 'ACL' or 'Australian Consumer Law' means Schedule 2 to the Competition and Consumer Act 2010;
- (b) 'Appliance' means any Electrolux product purchased by you and accompanied by this document;
- (c) 'ASC' means Electrolux's authorised serviced centres;
- (d) 'BeefEater' is the brand controlled by Electrolux Home Products Pty Ltd of 163 O'Riordan Street, Mascot NSW 2020, ABN 51 004 762 341 in respect of Appliances purchased in Australia and Electrolux (NZ) Limited (collectively "Electrolux") of 3-5 Niall Burgess Road, Mount Wellington, in respect of Appliances purchased in New Zealand;
- (e) 'Warranty Period' means the period specified in clause 3 of this warranty;
- (f) 'you' means the purchaser of the Appliance not having purchased the Appliance for re-sale, and 'your' has a corresponding meaning.

2. Application: This warranty only applies to new Appliances, purchased and used in Australia or New Zealand and is in addition to (and does not exclude, restrict, or modify in any way) other rights and remedies under a law to which the Appliances or services relate, including any non-excludable statutory guarantees in Australia and New Zealand.

3. Warranty Period: Subject to these terms and conditions, this warranty continues for in Australia for a period of 12 months and in New Zealand for a period of 12 months, following the date of original purchase of the Appliance. Specific components are warranted against manufacturing defects in Australia and New Zealand for the periods listed below;

- Burner Box - Further 4 years parts only

4. Repair or replace warranty: During the Warranty Period, Electrolux or its ASC will, at no extra charge if your Appliance is readily accessible for service, without special equipment and subject to these terms and conditions, repair or replace any parts which it considers to be defective. Electrolux may, in its absolute discretion, choose whether the remedy offered for a valid warranty claim is repair or replacement. Electrolux or its ASC may use refurbished parts to repair your Appliance. You agree that any replaced Appliances or parts become the property of Electrolux.

5. Travel and transportation costs: Subject to clause 7, Electrolux will bear the reasonable cost of transportation, travel and delivery of the Appliance to and from Electrolux or its ASC. Travel and transportation will be arranged by Electrolux as part of any valid warranty claim.

6. Proof of purchase is required before you can make a claim under this warranty.

7. Exclusions: You may not make a claim under this warranty unless the defect claimed is due to faulty or defective parts or workmanship. This warranty does not cover:

- (a) light globes, batteries, filters or similar perishable parts;
- (b) parts and Appliances not supplied by Electrolux;

- (c) cosmetic damage which does not affect the operation of the Appliance;
- (d) damage to the Appliance caused by:
 - (i) negligence or accident;
 - (ii) misuse or abuse, including failure to properly maintain or service;
 - (iii) improper, negligent or faulty servicing or repair works done by anyone other than an Electrolux authorised repairer or ASC;
 - (iv) normal wear and tear;
 - (v) power surges, electrical storm damage or incorrect power supply;
 - (vi) incomplete or improper installation;
 - (vii) incorrect, improper or inappropriate operation;
 - (viii) insect or vermin infestation;
 - (ix) failure to comply with any additional instructions supplied with the Appliance;

In addition, Electrolux is not liable under this warranty if:

- (a) the Appliance has been, or Electrolux reasonably believes that the Appliance has been, used for purposes other than those for which the Appliance was intended, including where the Appliance has been used for any non-domestic purpose;
- (b) the Appliance is modified without authority from Electrolux in writing;
- (c) the Appliance's serial number or warranty seal has been removed or defaced.

8. How to claim under this warranty: To enquire about claiming under this warranty, please follow these steps:

- (a) carefully check the operating instructions, user manual and the terms of this warranty;
- (b) have the model and serial number of the Appliance available;
- (c) have the proof of purchase (e.g. an invoice) available;
- (d) telephone the numbers shown below.

9. Australia: For Appliances and services provided by Electrolux in Australia: Electrolux goods come with guarantees that cannot be excluded under the Australian Consumer Law. You are entitled to a replacement or refund for a major failure and for compensation for any other reasonably foreseeable loss or damage. You are also entitled to have the Appliance repaired or replaced if the Appliance fails to be of acceptable quality and the failure does not amount to a major failure. 'Acceptable quality' and 'major failure' have the same meaning as referred to in the ACL.

10. New Zealand: For Appliances and services provided by Electrolux in New Zealand, the Appliances come with a guarantee by Electrolux pursuant to the provisions of the Consumer Guarantees Act, the Sale of Goods Act and the Fair Trading Act. Where the Appliance was purchased in New Zealand for commercial purposes the Consumer Guarantee Act does not apply.

11. Confidentiality: You accept that if you make a warranty claim, Electrolux and its agents including ASC may exchange information in relation to you to enable Electrolux to meet its obligations under this warranty.

Important Notice

Before calling for service, please ensure that the steps listed in clause 8 above have been followed.

<p>FOR SERVICE or to find the address of your nearest authorised service centre in Australia PLEASE CALL 1300 307 939 For the cost of a local call (Australia only)</p>	<p>AUSTRALIA ELECTROLUX HOME PRODUCTS 163 O'Riordan Street, Mascot NSW 2020 beefeaterbbq.com.au</p>	<p>FOR SPARE PARTS or to find the address of your nearest spare parts centre in Australia PLEASE 13 13 50 For the cost of a local call (Australia only)</p>
<p>FOR SERVICE or to find the address of your nearest authorised service centre in New Zealand PLEASE CALL 0800 10 66 10 (New Zealand only)</p>	<p>NEW ZEALAND ELECTROLUX (NZ) Limited 3-5 Niall Burgess Road, Mount Wellington beefeaterbbq.co.nz</p>	<p>FOR SPARE PARTS or to find the address of your nearest spare parts centre in New Zealand PLEASE 0800 10 66 20 (New Zealand only)</p>

For more information on all BeefEater products, or for dimension and installation information, call into your retailer, phone or email our customer care team or visit our website:

AUSTRALIA

phone: 1300 307 939

fax: 1800 356 669

email: customercare@electrolux.com.au

web: beefeaterbbq.com

NEW ZEALAND

phone: 0800 436 245

fax: 0800 225 088

email: customercare@electrolux.co.nz

web: beefeaterbbq.com

BeefEater. We are part of the Electrolux Family.
To add a touch of professional inspiration to
your home, visit electrolux.com.au