

## CLUBMAN BBQ NATURAL GAS CONVERSION KIT

### Kit Model 95166 includes:

- 4 x 1.95mm injectors (Part No. 040174)
- 1 x Natural Gas Label
- 1 x Hose and Regulator assembly (Part No. 95162)

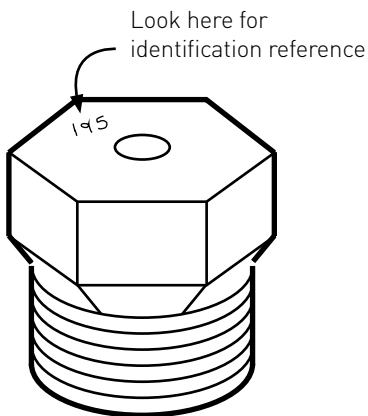

Please read the user manual carefully and store in a handy place for later reference.

### Important Safety Instructions



All service to the appliance must be undertaken by a qualified gas service agent.

Do not smoke or use a naked flame within the vicinity of the appliance or gas line when performing gas conversion or service of any kind.

Always carry out a gas leak test after any work has been carried out on the appliance.

If your barbecue is fitted with an optional side burner, gas conversion must be carried out at the same time.

Always use the correct size socket spanner / wrench to remove or replace the gas injectors. Do not use pliers or any other type of tool that may squeeze the head of the gas injector. This may cause the gas orifice to change shape thereby adversely affecting the gas flow to each burner.

Gas injectors are made of brass and have a fine thread which must be treated with care when being handled. Remove and replace injectors with care.



The manufacturer accepts no responsibility for any consequential damage, malfunction or loss due to incorrect conversion or installation.

**FAILURE TO FOLLOW THESE INSTRUCTIONS WILL VOID THE APPLIANCE WARRANTY.**

### Remove and Replace Gas Injectors (Jets)

1. Turn off the gas supply valve on the gas cylinder. Ensure that all gas controls on the BBQ are in the OFF position.
2. Disconnect the hose and regulator from the gas cylinder and disconnect the gas hose from the barbecue gas inlet using a 19mm open-ended spanner / wrench.
3. Remove any cover and the cooking plate from the BBQ.
4. Remove the 'R' shaped locking clips that hold each burner in place and remove all burners from the BBQ.
5. The gas injectors (Jets) for each burner are located within deep pockets behind the front firewall of the BBQ. See below illustration.

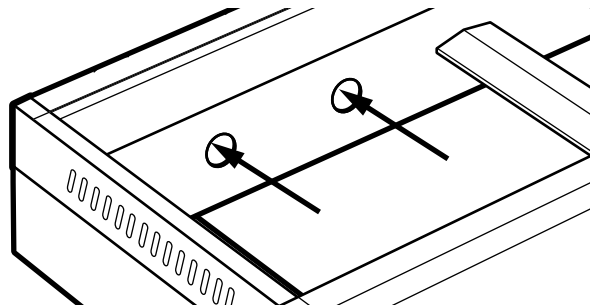

6. Remove each gas injector from the end of each valve body, turning gently in a counter clockwise direction. Be careful not to block the orifice at the end of the valve where the gas injector is fitted and do not remove any of the thread sealing compound from the orifice where the injector is located.
7. Check the identification mark stamped on the Hex Head of the injector to confirm that it is the correct size – Main Burners: 1.95mm. Screw correct Jets back into place.
8. When fitting the NG gas injectors to the end of the valve body be sure to seat the injector correctly on the thread before turning it in a clockwise direction until it is seated firmly in place. Do not over-tighten.

## Adjust Aeration Screw in Burners

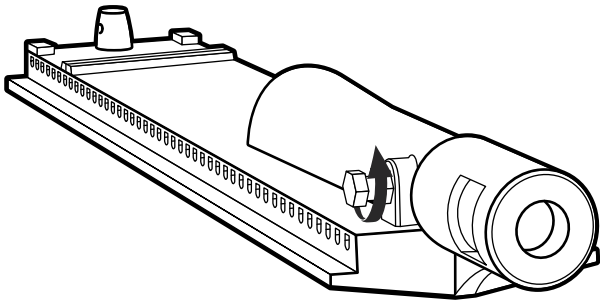

At the air entry side of each burner turn the aeration screw anticlockwise until no thread is protruding into the burner; and lock into place with a locking nut. Do not completely remove the screw.

## Replace all parts into position in the BBQ

Refit the burners and secure with the locking clips that hold each burner in position. Replace the cooking plate.

**NOTE: Check the operation of each burner**

## Gas Leak Test Procedure

Use the following procedure to check for gas leaks. Never use a naked flame to check for gas leaks.

1. In a small container, mix up a solution of water and detergent or soap. Mix the solution well.
2. For LPG make sure that the gas supply valve on the gas cylinder is turned on. For NG make sure that the gas line is correctly fitted to the appliance.
3. Make sure that the gas control valves on the appliance are all turned off.
4. Using a brush or spray bottle apply the solution to the gas line and each join in the gas line.
5. Bubbling of the solution will indicate that there is a leak present.
6. Re-tighten or re-seal any joints that are leaking.
7. If a leak persists then contact your distributor or the manufacturer for assistance.

## Use the following procedure to test the pressure

8. Remove the far left burner.
9. Place a hose and pressure gauge over the control valve's injector.
10. Turn all other burners on, including the side burner.
11. Turn the LH valve with measuring device on as well, and take reading.
12. With a minimum of 3 burners operating, the pressure reading for Natural Gas should be 1.00KPa (10 mbar).

## Replace the Data Label

Peel the gas type label from backing and cover existing data label to indicate Natural Gas.



### WARNING

If you smell gas:

1. Shut off gas to the appliance.
2. Extinguish any open flame.
3. Open lid.
4. If odour continues, immediately call your gas supplier or your fire department.



### WARNING

1. Do not store or use gasoline or other flammable vapours or liquids in the vicinity of this or any other appliance.
2. An LPG cylinder not connected for use shall not be stored in the vicinity of this or any other appliance.

## Technical Data Clubman BBQ

Clubman BBQ	Main Burner
Natural Gas Jet size	1.95mm
LPG Jet size	1.2mm
Gas consumption	18Mj
Inlet pressure	NG: 1KPa LPG: 2.75 KPa

For more information on all BeefEater products, or for dimension and installation information, call into your retailer, phone or email our customer care team or visit our website:

### AUSTRALIA

phone: 1300 307 939  
fax: 1800 356 669  
email: [customercare@electrolux.com.au](mailto:customercare@electrolux.com.au)  
web: [beefeaterbbq.com](http://beefeaterbbq.com)

### NEW ZEALAND

phone: 0800 436 245  
fax: 0800 225 088  
email: [customercare@electrolux.co.nz](mailto:customercare@electrolux.co.nz)  
web: [beefeaterbbq.com](http://beefeaterbbq.com)