

BBQ AND SIDE BURNER GAS CONVERSION INSTRUCTIONS

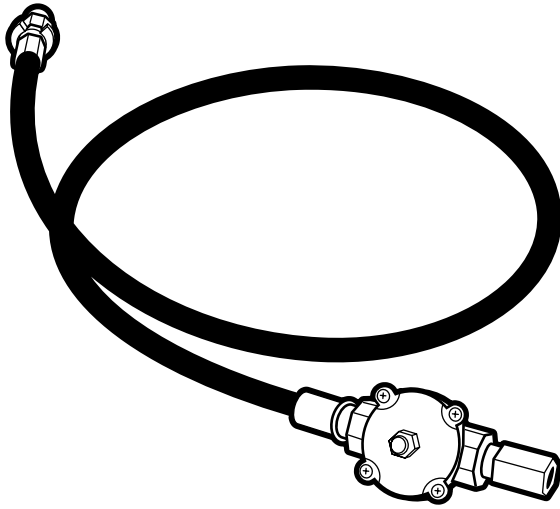

95164K

DISCOVERY i-1000 NATURAL GAS CONVERSION KIT

Suits Discovery Series (2002 onwards)

Kit includes:

- 1 x NG Hose and Regulator (Sold separately in USA)
- 5 x 1.9mm Injectors Hex N/G M5 Thread (code: 040145)
- 1 x 1.7mm Injector Hex N/G M5 Thread (code: 040170)
- 1 x NG Label (code: 020404) SL4000 Series

95170K and 95170SL

SIGNATURE 3000S AND SL4000 NATURAL GAS CONVERSION KIT

Suits the following BeefEater models:

Signature S-3000 Series (August 2002 onwards)
Balcony Series (August 2002 onwards)

Kit includes:

- 1 x N/G Hose and regulator (Sold separately in USA)
 - 6 x 2.10mm Hex Head N/G injectors M5 Thread
 - 1 x Pilot jet Injector 0.95mm 040259
– previously 95170SL only
- (Not required for Signature 3000S)
- 1 x NG Label (code: 020404)

95167

SIGNATURE 3000E NATURAL GAS CONVERSION KIT

Suits models from 2011 onwards

Kit includes:

- 1 x Label "NATURAL GAS" Black 020404
- 5 x Injector NG 2.10 mm M6 040178
- 1 x Injector NG 2.10 mm M5 040168
- 1 x Nat/Gas Hose & Reg PVC 750mm 95162
(Sold separately in USA)

Important Safety Instructions



WARNING

All service to the appliance must be undertaken by a qualified gas service agent.

Do not smoke or use a naked flame within the vicinity of the appliance or gas line when performing gas conversion or service of any kind.

Always carry out a gas leak test after any work has been carried out on the appliance.

If your barbecue is fitted with an optional side burner, gas conversion must be carried out at the same time.

Always use the correct size socket spanner / wrench to remove or replace the gas injectors. Do not use pliers or any other type of tool that may squeeze the head of the gas injector. This may cause the gas orifice to change shape thereby adversely affecting the gas flow to each burner.

Gas injectors are made of brass and have a fine thread which must be treated with care when being handled. Remove and replace injectors with care.

BBQ AND SIDE BURNER GAS CONVERSION INSTRUCTIONS

DISCOVERY i-1000 SERIES

LPG to Natural Gas Conversion

1. Removing And Replacing Gas Injectors

- Turn off the gas supply valve on the gas cylinder. Ensure that all gas controls on the barbecues are in the OFF position.
- Disconnect the hose and regulator from the gas cylinder and disconnect the gas hose from the barbecue gas inlet using a 19mm open-ended spanner / wrench.
- Remove all cooking plates, grills, and Vaporizers from the barbecue.
- Remove the 'R' shaped locking clips that hold each burner in place and remove all burners from the barbecue. This needs to be done at the rear of the BBQ.
- The gas injectors for each burner are located within deep pockets on the front firewall of the barbecue.

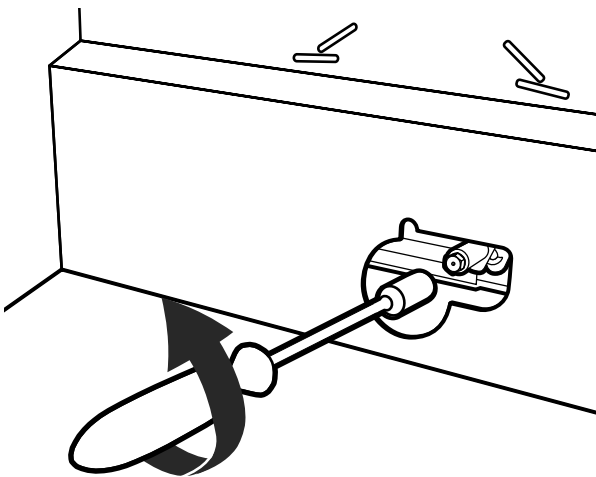

Remove each gas injector from the end of each valve body using a 6mm socket spanner / wrench, turning gently in a counter clockwise direction.

Be careful not to block the orifice at the end of the valve where the gas injector is fitted and do not remove any of the thread sealing compound from the orifice where the injector is located.

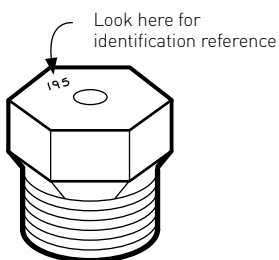

Check the identification mark stamped on the Hex Head of the injector to confirm that it is the correct size (NG: 1.90mm) before proceeding to fit it into the valve.

When fitting the NG gas injectors to the end of the valve body be sure to seat the injector correctly on the thread before turning it in a clockwise direction until it is seated firmly in place. Do not over tighten.

2. Adjusting Low Flame Control Screw



IMPORTANT

For 3000E - Valves do not have Low-Flame adjustment screw, and are adjusted at factory.

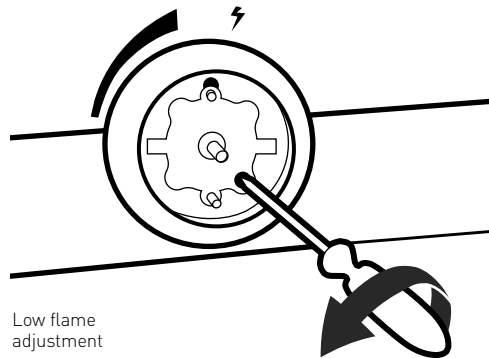

Low flame adjustment

The low flame adjustment must be carried out for each burner. The low flame adjustment screw in Ignition valves is located on the lower right hand corner of the front of the valve body. The screw can be accessed from the front of the BBQ by removing the control knob of each burner. To set the low flame adjustment for Natural Gas, use a 4mm wide, flat blade screwdriver.

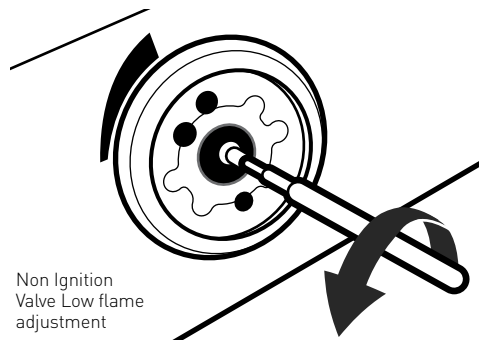

Non Ignition Valve Low flame adjustment

To set the Natural Gas low flame adjustment for Non Ignition Valves: Use a 2.5mm wide, flat blade screwdriver. The screw is located inside the knob spindle.

The Low flame adjustment screw must be turned counter-clockwise $\frac{3}{4}$ turn.

3. Connecting the Natural Gas Hose and Regulator.

Connect the Natural Gas hose and regulator (where applicable) to the gas inlet on the barbecue using a 19mm spanner / wrench. Tighten firmly but do not over tighten.

Connect gas regulator to gas source line and perform a gas leak test as per instructions in the barbecue operating and assembly instructions.

4. Replace all Burners into Position in the Barbecue.

Refit the locking clips that hold each burner in position. Replace all Vaporizers, cooking plates and grills.

Check the operation of each burner. It may be required to open the Air-Mixture screw, located at the burner venture, a couple of turns to get the correct flame.

5. Change the gas type label.

Peel the "Natural Gas" gas Type label from backing sheet and place this over the existing LPG Gas label to indicate that the unit is configured for Natural Gas.

6. Side Burner

Side burner uses the 1.7mm injector. Other details are same as described for main burners above.

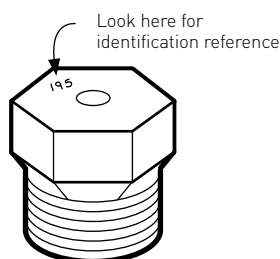

Check the identification mark stamped on the Hex Head of the injector to confirm that it is the correct size (NG: 2.10mm) before proceeding to fit it into the valve.

When fitting the NG gas injectors to the end of the valve body be sure to seat the injector correctly on the thread before turning it in a clockwise direction until it is seated firmly in place. Do not over tighten.

SIGNATURE SERIES LPG to Natural Gas Conversion

1. Removing And Replacing Gas Injectors

- Turn off the gas supply valve on the gas cylinder. Ensure that all gas controls on the barbecues are in the OFF position.
- Disconnect the hose and regulator from the gas cylinder and disconnect the gas hose from the barbecue gas inlet using a 19mm open-ended spanner / wrench.
- Remove all cooking plates, grills, Vaporizers and heat reflectors (where fitted) from the barbecue.
- Remove the 'R' shaped locking clips that hold each burner in place and remove all burners from the barbecue. This needs to be done at the rear of the BBQ.

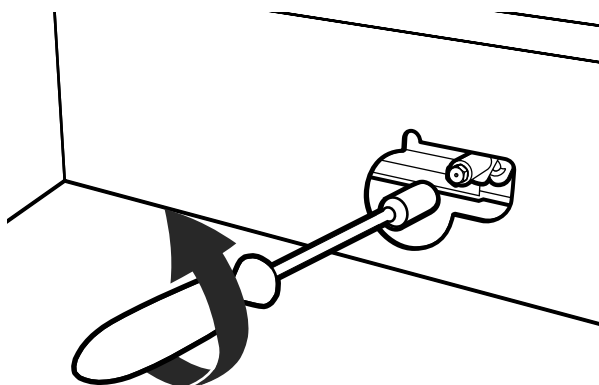

The gas injectors for each burner are located within deep pockets on the front firewall of the barbecue. Remove each gas injector from the end of each valve body using a 6mm socket spanner / wrench, turning gently in a counter clockwise direction.

Be careful not to block the orifice at the end of the valve where the gas injector is fitted and do not remove any of the thread sealing compound from the orifice where the injector is located.

2. Adjusting Low Flame Control Screw

The low flame adjustment must be carried out for each burner. The low flame adjustment screw is located on the lower right hand corner of the front of the valve body. The screw can be accessed from the front of the BBQ by removing the control knob of each burner.

To set the low flame adjustment for NG, use a 4mm wide, flat blade screwdriver.

The Low flame adjustment screw must be turned counter-clockwise 3/4 turn.

NOTE: For Signature 3000E, no adjustment is needed

3. Connecting The Natural Gas Hose And Regulator

Connect the Natural gas hose and regulator (where applicable) to the gas inlet on the barbecue using a 19mm spanner / wrench. Tighten firmly but do not over tighten. Connect gas regulator (if required) to the gas source line and perform a gas leak test as per instructions in the barbecue operating and assembly instructions, or see page 4 of this instruction manual.

4. Replace All Burners into Position in the Barbecue

Refit the locking 'R' clips that hold each burner in position. Replace all vaporizers, cooking plates and grills. Check the operation of each burner. It may be required to open the Air-Mixture screw, located at the burner venture, a couple of turns to get the correct flame.

5. Change the gas type label.

Peel the "Natural Gas" gas Type label from backing sheet and place this over the existing LPG Gas label to indicate that the unit is configured for Natural Gas.

6. Side Burner

Side burner uses same injector as main burners*, and converted in same manner as above.

* On the SL4000 Side Burner, also need to replace the Pilot Nozzle. see last page for details.

NOTE: To convert from NG to LPG, reverse the above steps.

BBQ AND SIDE BURNER GAS CONVERSION INSTRUCTIONS



GAS LEAK TEST PROCEDURE

Use the following procedure to check for gas leaks.

Never use a naked flame to check for gas leaks.

1. In a small container, mix up a solution of water and detergent or soap. Mix the solution well.
2. For LPG make sure that the gas supply valve on the gas cylinder is turned on. For NG make sure that the gas line is correctly fitted to the appliance.
3. Make sure that the gas control valves on the appliance are all turned off.
4. Using a brush or spray bottle apply the solution to the gas line and each join in the gas line.

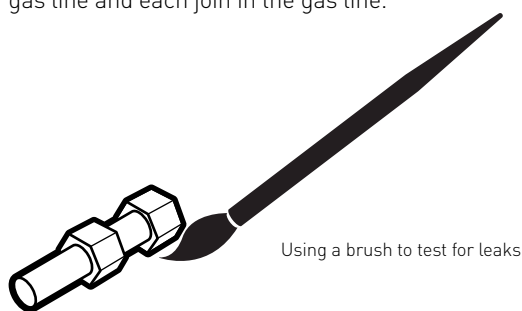

5. Bubbling of the solution will indicate that there is a leak present.
6. Re-tighten or re-seal any joints that are leaking.
7. If a leak persists then contact your distributor or the manufacturer for assistance.

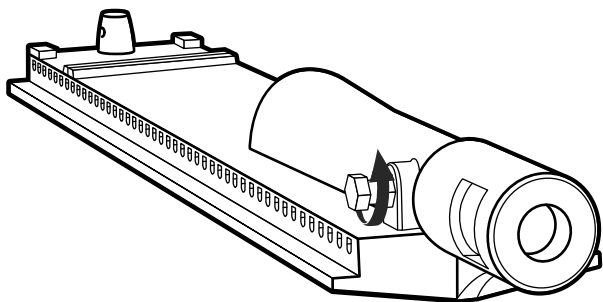

Aeration Screw Adjustment

Refer to the specific BBQ manual for any other technical information required

WARNING

If you smell gas:

1. Shut off gas to the appliance.
2. Extinguish any open flame.
3. Open lid.
4. If odour continues, immediately call your gas supplier or your fire department.

WARNING

1. Do not store or use gasoline or other flammable vapours or liquids in the vicinity of this or any other appliance.
2. An LPG cylinder not connected for use shall not be stored in the vicinity of this or any other appliance.

SL4000 Side Burner Pilot Injector Replacement:

On the side-burner, remove the valve assembly from the manifold, disassemble the pilot ignition tube (one screw), un-screw the pilot jet and replace it with the NG jet (0.95mm) supplied in your NG kit.

Once done, reassemble the pilot ignition tube to the valve and then reinstall the valve assembly to the manifold in the side burner.

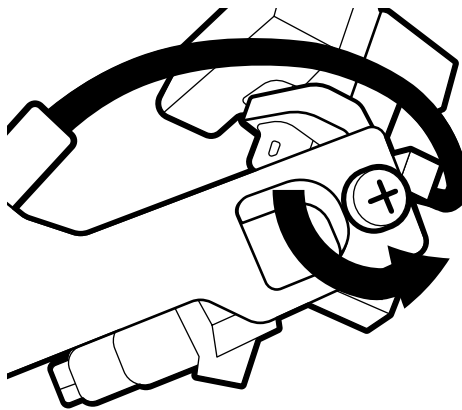

Side Burner Pilot Injector Replacement

For more information on all BeefEater products, or for dimension and installation information, call into your retailer, phone or email our customer care team or visit our website:

AUSTRALIA

phone: 1300 307 939
fax: 1800 356 669
email: customercare@electrolux.com.au
web: beefeaterbbq.com

NEW ZEALAND

phone: 0800 436 245
fax: 0800 225 088
email: customercare@electrolux.co.nz
web: beefeaterbbq.com