

540MM AND 600MM SLOT-IN UPRIGHT RANGE COOKER

WFE517, WFE547, WFE616, WFE619
WFE642, WFE647, WFG617

CONGRATULATIONS

Congratulations and thank you for choosing our cooker. We are sure you will find your new appliance a pleasure to use and a great asset to your cooking. Before you use the appliance, we recommend that you read through the whole user manual which provides a description of the product and its functions.

To avoid the risks that are always present when an appliance is used, it is important that the appliance is installed correctly and that you read the safety instructions carefully to avoid misuse and hazards. For future reference, please store this booklet in a safe place.

This appliance complies with the requirements of Australian Standard AS/NZ 60335.2.6. Gas appliances also comply with the requirements of AS4551.

Conditions of Use

This appliance is intended to be used in household and similar applications such as:

- Staff kitchen areas in shops, offices and other working environments
- Farm houses
- By clients in hotels, motels and other residential type environments
- Bed and breakfast type environments

Record model and serial number here:

Model number:.....

Serial number:.....

Please read the user manual carefully and store in a handy place for later reference. The symbols you will see in this booklet have these meanings:



WARNING

This symbol indicates information concerning your personal safety



CAUTION

This symbol indicates information on how to avoid damaging the appliance



TIPS AND INFORMATION

This symbol indicates tips and information about use of the appliance



ENVIRONMENT

This symbol indicates tips and information about economical and ecological use of the appliance

CONTENTS

Important safety instructions.....	3
Description of your appliance.....	4
Before operating your appliance for the first time.....	6
Installing your oven accessories.....	7
Using the hotplate.....	8
Operating for the first time.....	9
Using the gas cooker.....	10
General hints and tips.....	12
Guide to better grilling.....	13
Operating the 120min mechanical timer.....	14
Using the oven.....	15
Oven guide.....	16
Cake test.....	17
Cooking problems.....	18
Cleaning.....	19
Solving problems.....	23
Installing the appliance.....	24
600mm.....	26
540mm.....	28
Connections.....	29
LPG conversion.....	32
Testing the operation of the gas cooker.....	34
Warranty.....	35



TIPS AND INFORMATION

Important - CHECK FOR ANY DAMAGE OR MARKS

If you find the appliance is damaged or marked, you must report it within 7 days if you wish to claim for damage/marks under the manufacturer's warranty. This does not affect your statutory rights.



ENVIRONMENT

Information on disposal for users

- Most of the packing materials are recyclable. Please dispose of those materials through your local recycling depot or by placing them in appropriate collection containers.
- If you wish to discard this product, please contact your local authorities and ask for the correct method of disposal.

IMPORTANT INFORMATION THAT MAY IMPACT YOUR MANUFACTURER'S WARRANTY

Adherence to the directions for use in this manual is extremely important for health and safety. Failure to strictly adhere to the requirements in this manual may result in personal injury, property damage and affect your ability to make a claim under the Westinghouse manufacturer's warranty provided with your product. Products must be used, installed and operated in accordance with this manual. You may not be able to claim on the Westinghouse manufacturer's warranty in the event that your product fault is due to failure to adhere this manual.

IMPORTANT SAFETY INSTRUCTIONS



WARNING

- This appliance is not intended for use by persons (including children) with reduced physical, sensory or mental capabilities, or lack of experience and knowledge, unless they have been given supervision or instruction concerning use of the appliance by a person responsible for their safety.
- Children should be supervised to ensure that they do not play with the appliance.
- During use, this appliance becomes hot. Care should be taken to avoid touching hot surfaces, e.g. oven door, heating elements or internal surfaces of the oven.
- This appliance must not be used as a space heater.
- In order to avoid a fire, the appliance must be kept clean and vents kept unobstructed.
- Do not spray aerosols in the vicinity of the appliance during operation.
- Do not use or store flammable materials in or under the appliance, e.g. Aerosols.
- Accessible parts will become hot when in use. To avoid burns and scalds children should be kept away.
- Do not line the bottom of the oven or grill with foil or cookware.
- Always use gloves when handling hot items inside grill or oven.
- Do not use harsh abrasive cleaners or sharp metal scrapers to clean the oven door glass since they can scratch the surface, which may result in shattering of the glass.
- Do not modify this appliance.
- The appliance is not intended to be operated by means of an external timer or separate remote control system.
- Do not store items on the cooking surfaces. This may result in a fire.
- Accessible parts may become hot during use. Young children should be kept away.
- The cooking process has to be supervised. A short term cooking process has to be supervised continuously.
- Unattended cooking on a hob with fat or oil can be dangerous and may result in a fire.
- The appliance must not be installed behind a decorative door in order to avoid overheating.

Grill

- Always turn the grill off immediately after use as fat left there may catch fire.
- Always keep the grill dish clean as any fat left may catch fire.
- Do not leave the grill on unattended.
- To avoid a fire, ensure that grill trays and fittings are always inserted into the appliance in accordance with the instructions.

- Do not place thick portions of food under the grill. Foods may curl, catch and ignite.
- Accessible parts may become hot when grill is in use. Children should be kept away.

Oven

- During use the appliance becomes hot. Care should be taken to avoid touching the hot surfaces inside the oven.
- Switch the appliance off before removing the oven light glass for globe replacement.
- To avoid an accident, ensure that oven shelves and fittings are always inserted into the appliance in accordance with the instructions.
- Do not use the door as a shelf.
- Do not push down on the open oven door.

Installation, cleaning and servicing

- An authorised person must install this appliance. (Certificate of Compliance to be retained)
- Before using the appliance, ensure that all packing materials are removed from the appliance.
- In order to avoid any potential hazard, the enclosed installation instructions must be followed.
- Ensure that all specified appliance vents, openings and airspaces are not blocked.
- Where the appliance is built into a cabinet, the cabinet material must be capable of withstanding 85°C.
- Only authorised personnel should carry out servicing. (Certificate of Compliance to be retained)
- Always ensure the appliance is switched off before cleaning or replacing parts.
- Do not use steam cleaners, as this may cause moisture build up.
- Always clean the appliance immediately after any food spillage.
- To maintain safe operation, it is recommended that the product be inspected every five years by an authorised service person.
- If rigid gas pipe is used for installation it should include sufficient loops to allow the appliance to be removed from installed position without the need to disconnect the piping.
- This appliance must be earthed
- For appliances supplied with a supply cord, if the supply cord is damaged, it must be replaced by the manufacturer or its service agent or similarly qualified person in order to avoid a hazard.

DESCRIPTION OF YOUR APPLIANCE

Model WFE517

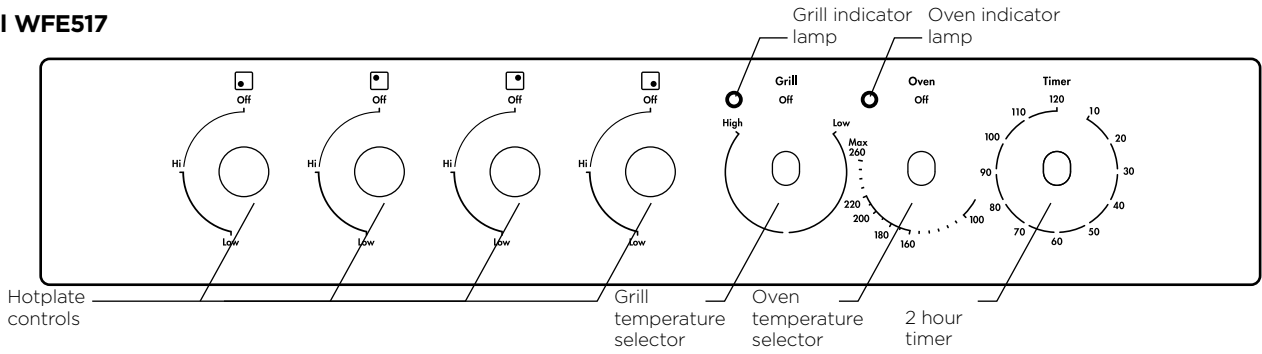

Model WFE547

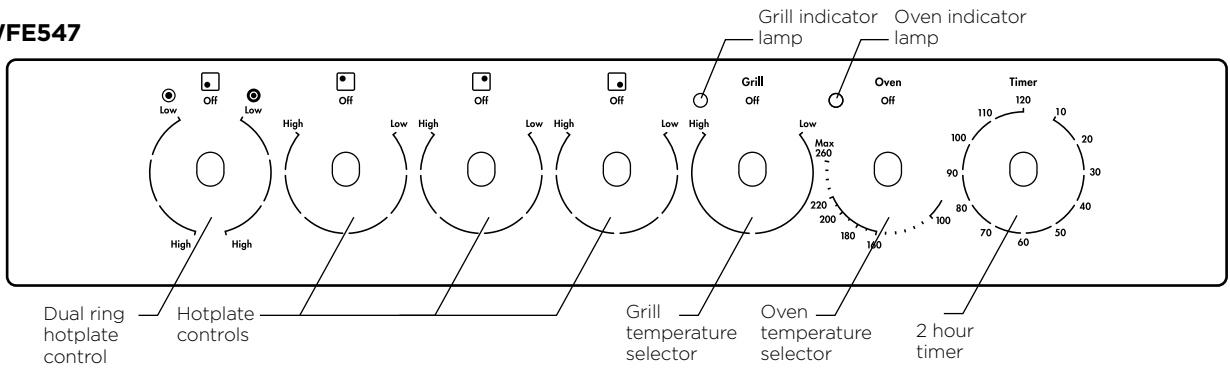

Model WFE616

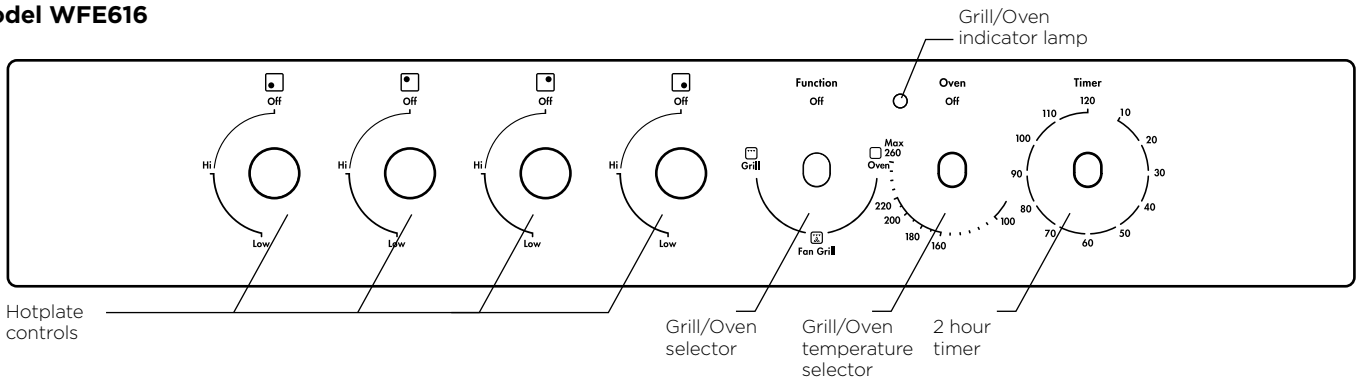

Model WFE619

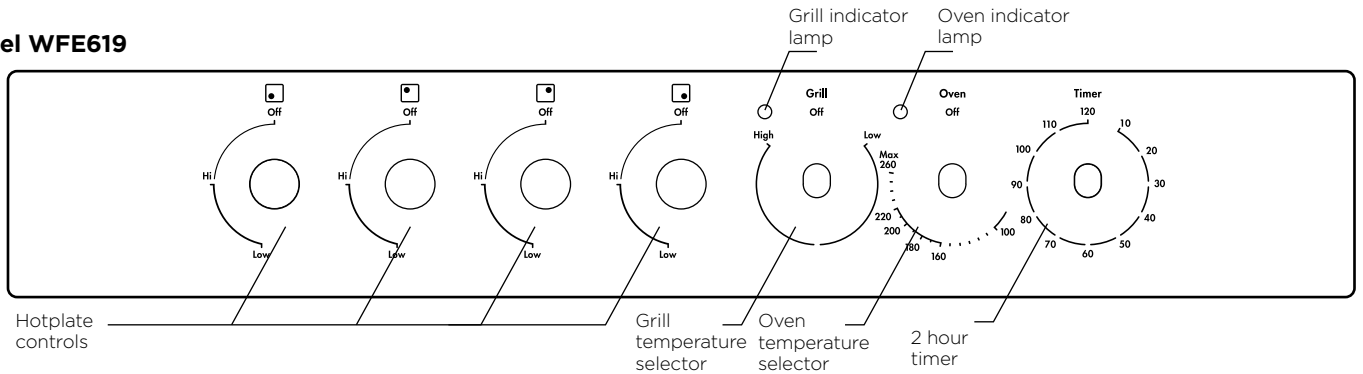

Model WFE642

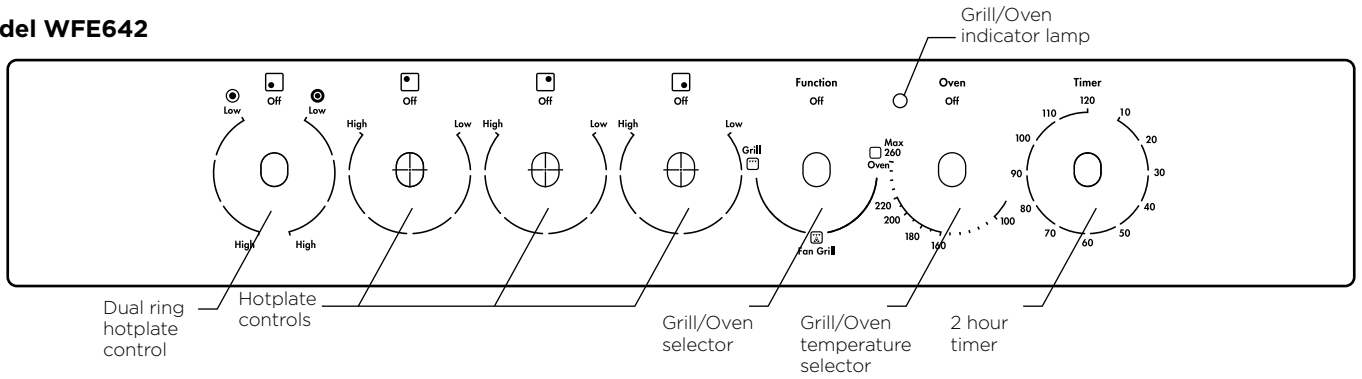

Model WFE647

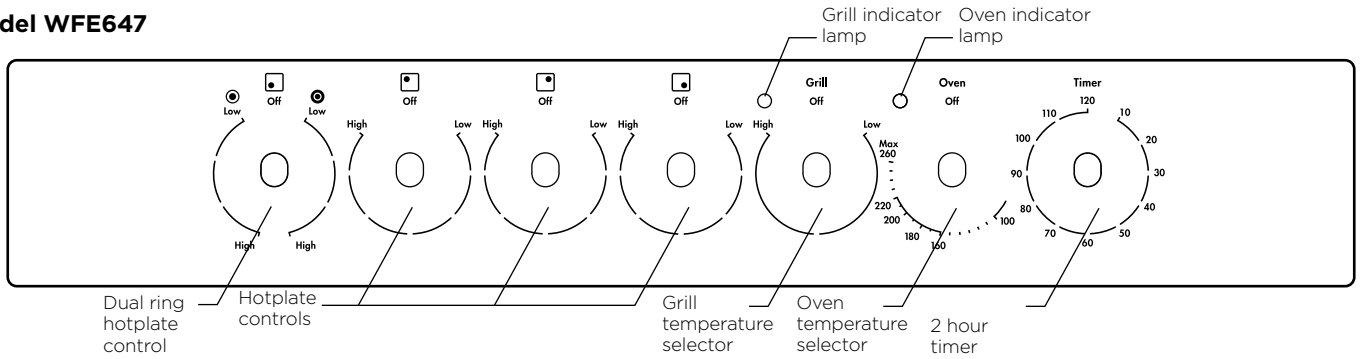

Model WFG617

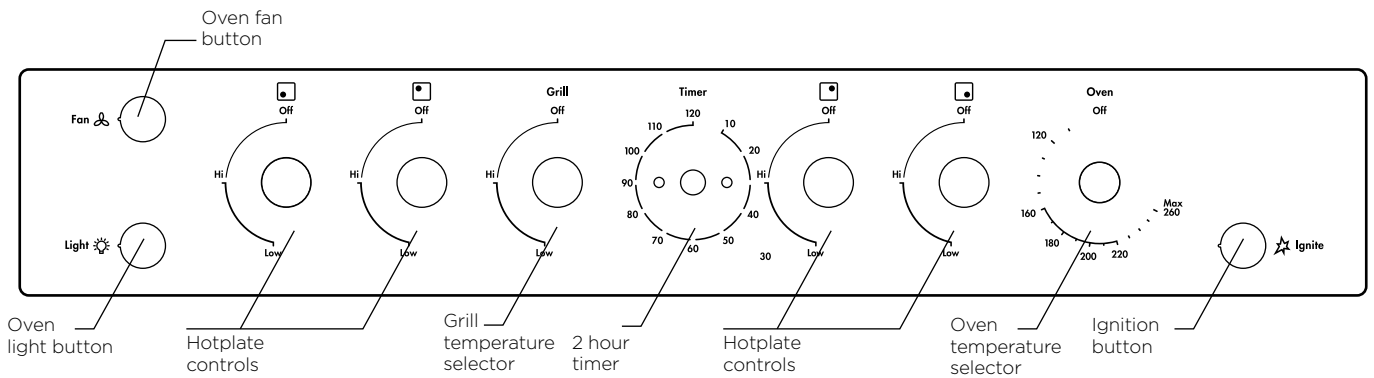

BEFORE OPERATING YOUR APPLIANCE FOR THE FIRST TIME

Preparing your appliance for the first time

- Please remove all internal boxes and bags from the oven before operation.
- Please wipe out the oven interior prior to operation with warm soapy water and polish dry with a soft clean cloth. Do not close the oven door until the oven is completely dry.



CAUTION

- Do not line the oven with foil as it will damage the enamel.
- New appliances can have an odour during first use. It is recommended to 'run in' the oven before cooking for the first time. Operate the oven(s), empty, at a temperature of 180°C for approximately 30 minutes. For appliances with a separate grill, run the grill on maximum for 15 minutes WITH GRILL DOOR OPEN. Please ensure that the room is well ventilated during this process.

Installing your oven accessories

Fitting oven shelves

1. Ensure shelf orientation is correct (refer to diagram below).
2. Slide oven shelves onto oven supports (side runners) at an angle until raised back of shelf is past the stop on oven supports (side runners).
3. Lower front of shelf and push in until stop is reached.
4. To remove oven shelves, withdraw to the stop and raise the front of shelf to clear the stop.

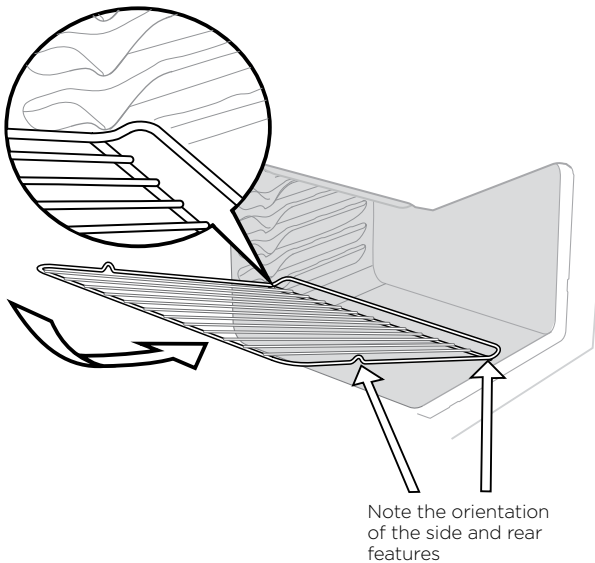

Grill in oven

(refer to Fitting Oven Shelves)

The grill dish with wire insert can be used in any of the two upper height positions (shelf positions 4 and 5) between the runners.

NOTE: You must remove the grill dish when baking in the oven.

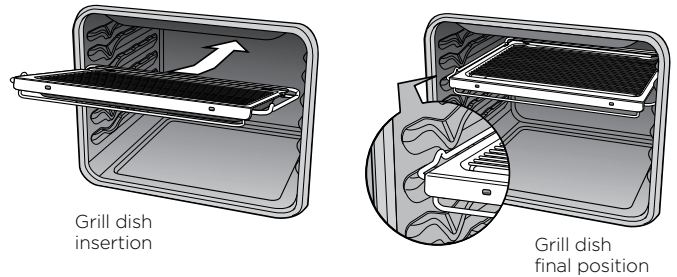

Oven shelf location

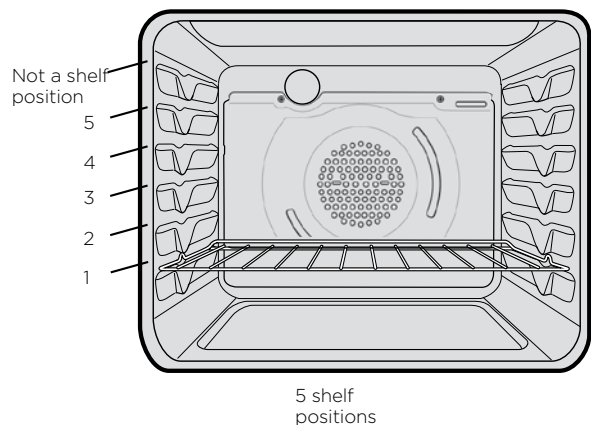

NOTE: The top ledge is not a shelf position. There are no stops for shelf withdrawal.

Separate grill

- To insert the grill tray in a separate grill underbench product, open the grill door and fully extend the grill drawer. Position the grill tray so that the slots on the outer edges fit over the tabs on the slides.

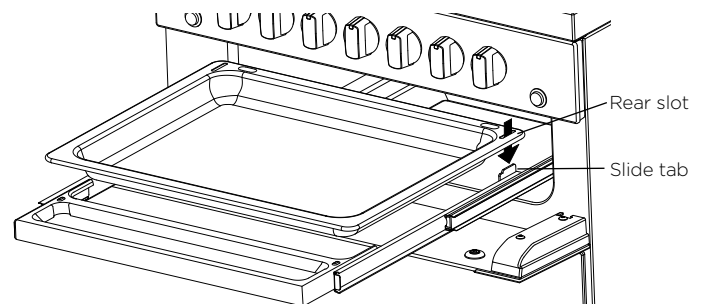

INSTALLING YOUR OVEN ACCESSORIES

Burner crowns and caps

- The burner crown must be fitted correctly into the burner cup or damage will occur during operation.
- To do this, ensure that the 2 ribs on either side of the spark plug hole are positioned into the 2 slots on the burner cup (see diagram).
- Burner cap and burner crown must be clean and located correctly for the burner to light.

NOTE: When the burner is correctly fitted it will sit level on the hob.

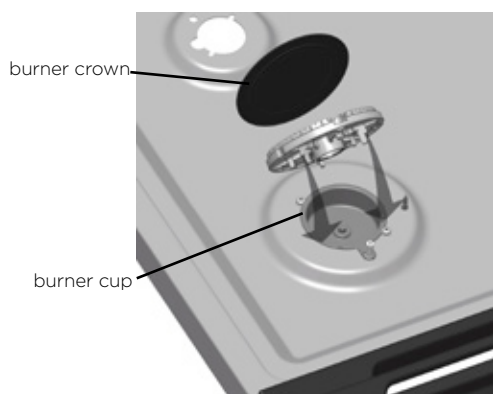

Trivets

- Take care when placing the trivets as dropping them may damage the hob or trivet.

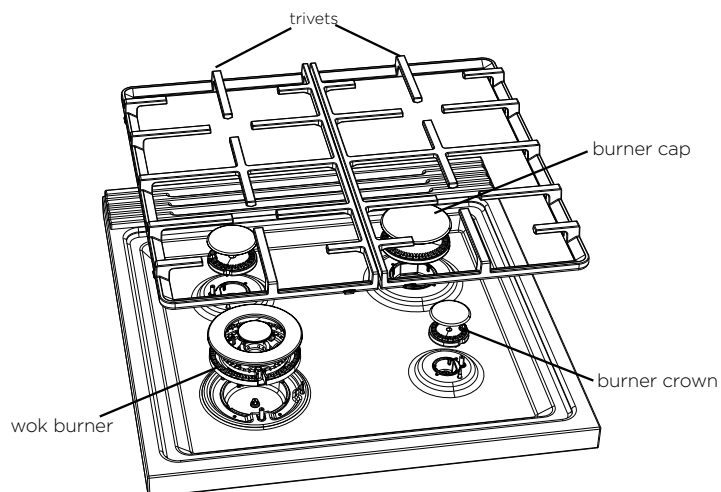

USING THE HOTPLATE

Hotplate dos and don't's

- Do not place heat resistant mats, wire mats or aluminium foil under pots and pans.
- Do not allow pots and pans to boil dry, as damage to both pan and hotplate may result.
- Do not use the hotplate as extra bench space or as a cutting board.
- Do not allow children on or near the cooktop at any time.
- Do not allow large cookware to overhang the hotplate onto the adjacent benchtop. This will cause scorching to the benchtop surface.
- Do not use round bottom woks or similar utensils which could lead to overheating of the hotplates and possible damage to the cooking surface.
- Use the stored heat in the hotplate by turning the control to off before the final few minutes of cooking.
- Do not slide pans across the surface of the ceramic glass as it could result in scratching of the surface.

Ceramic hotplates

The cooktop is made from ceramic glass, a tough, durable material that withstands heating and cooling without breaking. It is strong enough to hold the heaviest utensils. However, it must be remembered that as it is GLASS, it may break. Treat it accordingly!

Should you have any questions about the glass in your new appliance, please contact the service centre by dialling 13 13 49.

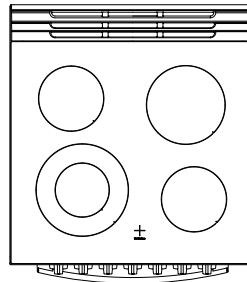

The heating elements are concealed under the smooth glass surface which has a pattern to show the location of the elements. When cooking, turn the control to the required setting.

The ceramic cooktop glass will retain heat for a period of time after the control is turned off. This will be indicated by the hot surface warning light which will continue to glow until the temperature drops below 60°C.

NOTE: If the ceramic glass is cracked switch off the appliance to avoid the possibility of electric shock.

- Use pans with smooth, clean and dry bottoms to avoid scratching or burning residue into the glass.
- Ensure the pan bottom is the same size as the working element.
- We do not recommend ceramic glass pans because they do not conduct heat well.
- Stainless steel or enamelled saucepans are best.
- Do not use pans with copper or aluminium bottoms because they can leave traces which are difficult to remove from the glass.
- If buying new utensils select enamelled steel pans with 2-3mm thick bottoms or stainless steel pans with sandwich bottoms 4-6mm thick. The pan bottom should be flat, or preferably, slightly concave at room temperature so that it lies flat on the glass surface when hot.

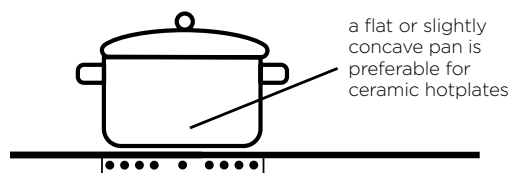

OPERATING FOR THE FIRST TIME

Choosing utensils for electric hotplates Refer to the diagram below.

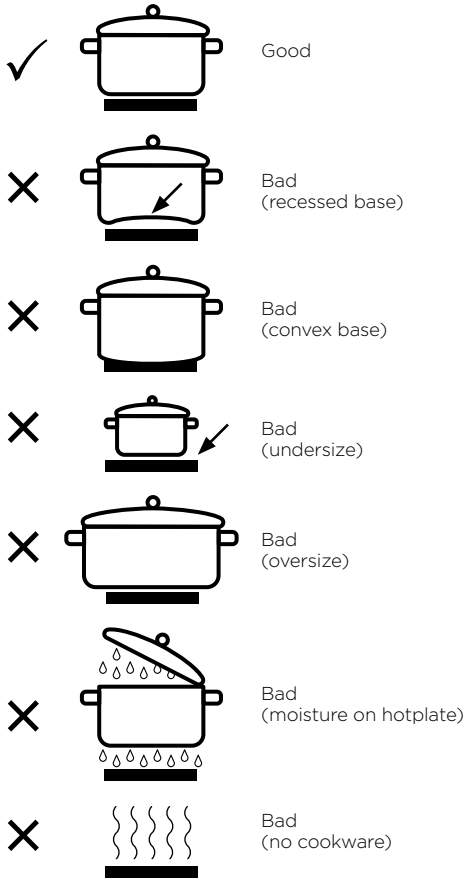

Choosing utensils for gas hotplates

Refer to the diagram below.

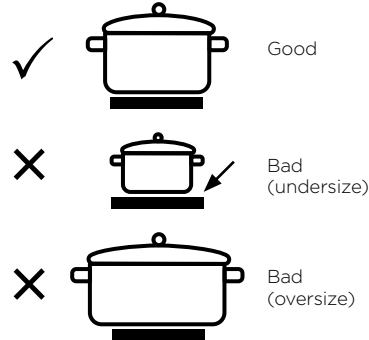

Do not use utensils which are too large or too small.

Installation and service warning

WARNING

- Only an authorised person must install and service this appliance (Certificate of Compliance to be retained).
- In order to avoid a hazard, the installation instructions **MUST** be followed.
- In order to avoid the appliance tipping, the anti-tilt plate **MUST** be installed.
- Appliances requiring connection to 230 – 240V **MUST** be earthed.
- An authorised person should inspect this appliance every 5 years.
- This appliance must **NOT** be installed on a base, box or in a closed cupboard.
- If the electrical supply cord is damaged, a qualified person **MUST** replace the cord to avoid a hazard.

WARNING

Surrounding kitchen cabinets **MUST WITHSTAND** 85°C.

BEFORE OPERATING FIRST TIME

1. Read all the Warning and Safety information.
2. Remove all internal boxes and bags from oven.
3. Clean out the oven interior with detergent and warm water and polish with a soft cloth. **DO NOT** close oven door until the oven is completely dry.

USING THE GAS COOKER

Gas hotplate

Ensure burner caps, crowns and trivets are properly assembled.

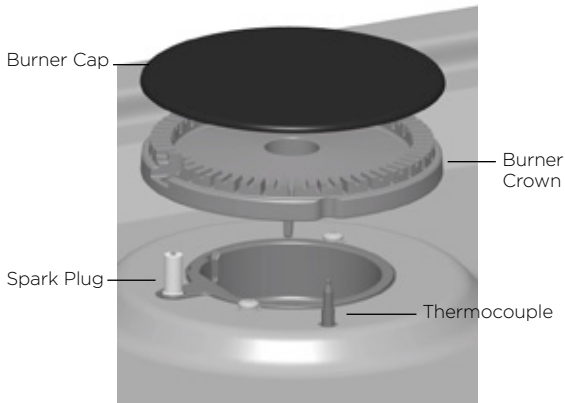
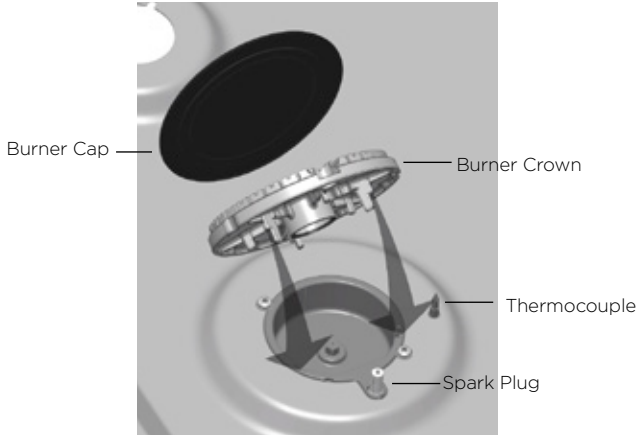

Gas oven burner flame

From a cold start the oven burner flame will be higher on the left hand-side. After reaching the set temperature, the flame will become even. This does not affect cooking results.

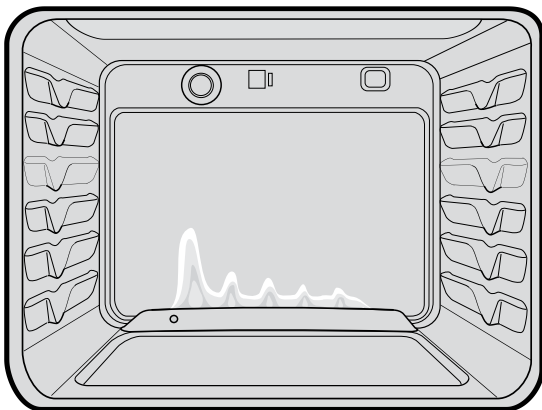

Lighting gas hotplate, grill and oven

Electronic ignition (For models WFE616, WFE619 and WFE517)

These hobs are fitted with mains powered electronic ignition. When the appliance has been connected and the power is on, depressing any knob will release sparks to all burners. To light a burner, depress the corresponding knob and while continuing to depress knob turn anticlockwise to 'HI' position. The knob may be released once the flame is established, and turned further anticlockwise to reduce the flame height as desired.

Push button Ignition (For models WFG617)

Turn appropriate burner control knob to maximum and at the same time press the ignition switch.★

Flame safeguard models (For models WFE616, WFE619, WFG617, WFE517)

Models with flame safeguard have the same ignition procedure as above but require the knob to continue to be depressed after flame is established for approximately 5 seconds. If the flame goes out when the knob is released, simply depress the knob again, this time holding it down with slightly more force for the same length of time.

⚠ WARNING

- Keep hands clear of burners when lighting.
- If burner does not light within 5 seconds, turn knob to 'Off' position, allow gas to disperse, then try lighting again.
- Burners MUST be operated between 'HIGH' and 'LOW' settings only.

🌿 ENVIRONMENT

To conserve gas, place the pan centrally over the burner and adjust the flame so that it does not go past the edge of the cookware.

NOTE: In the absence of electrical power, carry out the ignition directly to the burner with a hand held ignition source.

Grill ignition (For models WFG617)

Turn Grill Control Knob onto maximum and at the same time press Electronic Ignition Switch.★ This burner also has flame failure, so it is required to depress the knob approximately 5 seconds after the flame is established. If the flame goes out when the knob is released, simply depress the knob again, this time holding it down with slightly more force for the same length of time.

Grill - in oven

Grill is electric and is operated by control knob only.

Oven ignition - electronic (For model WFG617)

Push and hold Oven Control Knob onto desired temperature and at the same time press the Electronic Ignition Switch. Hold control knob in for 5 seconds after ignition.

USING THE GAS COOKER

Gas hotplates (Energy rating)

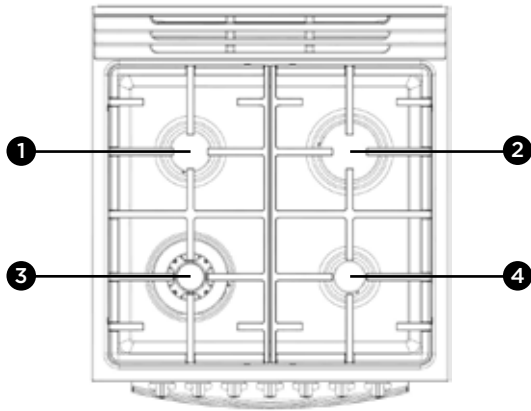

- 1** Medium heat burner (9.0 MJ/h)
Used for normal cooking and simmering with mid size cookware items.
- 2** High heat burner (12.1 MJ/h)
Used for fast heating with large size cookware items.
- 3** Intense heat wok burner (14.2 MJ/h)
Used for very fast heating with woks and other large size cookware items.
- 4** Low heat burner (5.1 MJ/h)
Used for simmering and for use with small cookware items.

NOTE: Energy ratings above are for natural gas (NG) models.

To conserve gas, place the pan centrally over the burner and adjust the flame so that it does not go past the edge of the cookware.

NOTE: In the absence of electrical power, carry out the ignition directly to the burner with a hand held ignition source.

GENERAL HINTS AND TIPS

General hints

For best baking results preheat oven for 30 minutes.

The material and finish of baking trays and dishes used will affect the way foods are baked, especially base browning.

- Enamelware, anodised aluminium, dark bakeware or non-stick interiors and coloured exteriors will assist in maintaining or reducing the baking time and increase base browning.
- Ovenproof glassware or ceramics are poor conductors of heat. The shiny surface of aluminium or polished steel utensils and trays also reflects the heat rather than passing it through to the food being baked.
- Always place dishes in the centre of the shelf to ensure even browning.
- Stand casserole dishes on a baking tray to prevent food from spilling onto the base of the oven.
- Use ovenproof cookware, which will withstand temperatures of 250°C.
- Use shallow casserole dishes in preference to deeper ones as this shortens cooking time in the oven.



CAUTION

- DO NOT place dishes, trays or baking pans directly on the oven base as they become very hot and will crack and craze the oven liner.
- DO NOT use baking trays larger than 30 x 35cm (12 x 14 inches) as they will restrict the circulation of the heat and may affect cooking performance of the oven.

Conventional Oven

- The shelf position is critical. The temperature in centre of the oven is the temperature shown on the oven control knob. Single shelf baking gives optimal cooking results.
- DO NOT place baking trays, oven dishes or foil directly on the base of oven, as trapped heat will crack and craze the floor of the oven liner.

Fan Forced

- Make sure shelves are evenly spaced.
- When baking more than one dish in fan forced oven, place dishes centrally on shelves rather than several dishes on one shelf.
- When the oven is full you may need to allow a slightly longer baking time.
- When using different size trays or cooking different types of food, cooking times may vary for each dish.



CAUTION

- DO NOT place baking trays and oven dishes directly against the grid covering the fan at the back of the oven.
- DO NOT place oven dishes directly on the oven base.



TIPS AND INFORMATION

Condensation and Steam

- During cooking steam may be produced which can be released when opening the oven door. This is quite normal.
- If there is any build-up of condensation on the oven door it is recommended that it be carefully wiped away either during or after cooking.



WARNING

Always stand back from heated oven when opening oven door to allow any build-up of steam or heat to release.



WARNING

Door glass is a tough and durable material designed to withstand heating and cooling without breaking. However it must be remembered that it is glass and may break, therefore must be treated with care. If you have any questions about the glass in the oven please contact the Service Centre on 13 13 49.

GUIDE TO BETTER GRILLING



CAUTION

Using the Grill

Separate Grill	Grill with door open. Grill dish must be located on slides. Slides must be fully pushed in while grilling.
Grill In Oven	Grill with door closed.



WARNING

Always clean the grill tray and grill tray insert after every use. Excessive fat build up may cause a fire.

For separate grill models, the door must be open while grilling. Ensure grill slides are fully inserted while grilling. Always switch the grill off immediately after use.

What is grilling?

- The grill directs heat from the heat source in the grill compartment onto the food.

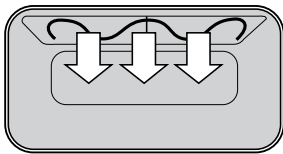

- This way of cooking traps the juices inside the food and increases the flavour.
- Grilling is suitable for tender cuts of meat, steak, chops, sausages, fish and other foods which cook quickly.

As a method of cooking, grilling can be used to:

- Enhance the flavours of vegetables, fish, poultry and meat.
- Seal the surface of the food and retain the natural juices.

This table shows how to grill different types of meat:

Beef	You can use tenderloin, rump, sirloin. Brush with oil or melted butter, especially if the meat is very lean.
Lamb	You can use loin chops, short loin chops, chump chops, and forequarter chops. Remove skin or cut at intervals to stop curling. Brush with oil or melted butter.
Sausages	Prick sausages to stop skin from bursting.
Poultry	Divide into serving pieces. Brush with oil.
Fish	Brush with oil or melted butter and lemon juice.
Bacon	Remove rind. Grill flat.

No definite times can be given for grilling because this depends on your own taste and the size of the food. These times should only be used as a guide and remember to turn the food over halfway through the cooking process.

Steak	15 - 20 minutes
Chops	20 - 30 minutes
Fish	8 - 10 minutes
Bacon	4 - 5 minutes

For better grilling results, follow these easy instructions:

- Preheat the grill for at least 3 minutes to obtain best results. This will help to seal the natural juices.
- Choose only prime cuts of meat or fish. If the cut is less than 5mm thick it will dry out. If the cut is more than 40mm thick, the outside may burn whilst the inside remains raw.
- Do not place aluminium foil under the food as this prevents fats and oils from draining away, which could result in a fire.
- Baste the food during cooking with butter, olive oil or marinade. Grilled food is better if marinated before cooking.
- Use tongs to turn food as a fork pierces the surface and will let juices escape.



WARNING

Safety warnings about the grill

- Do not cook food on the bottom of the grill compartment. Always use the grill dish and grill dish insert.
- Do not place foil under the food on the grill dish insert, as this prevents fats and oils running away and may cause a fire.
- Always use the grill parts according to instructions.
- Do not put thick pieces of food too near the element. They may curl and catch fire.
- Always turn the grill off immediately after cooking. Left-over fat may cause a fire.
- Always clean the grill dish and insert after use. Fat build up may cause a fire.
- Do not let children play with the grill.
- Do not let children use the grill without adult supervision.
- Do not leave the grill unattended when on.
- Be careful not to touch hot surfaces.
- Do not spray aerosols near the grill, when it is turned on.
- Do not keep flammable materials in or near the grill, eg chemicals, aerosols, etc.

OPERATING THE 120 MINUTE MECHANICAL RINGER TIMER (WHERE SUPPLIED)

Operating your 120 minute ringer timer

To set the timer, simply turn the knob clockwise to the required number of minutes.

Note: For any time below ten minutes, turn the knob past the thirty minute mark, then turn it back to the required number of minutes.

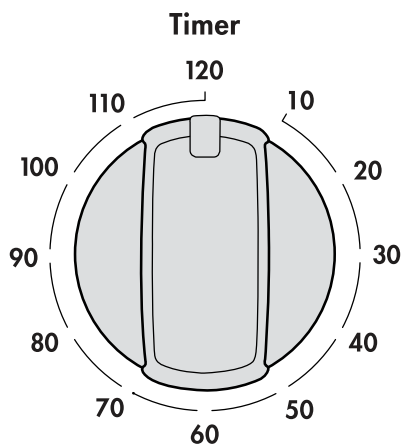

USING THE OVEN

Fan baking

The temperature in the oven is controlled by a thermostat. The fan distributes the heat throughout the oven compartment. This allows:

- Baking on all shelves at the same time with little variation in browning or cooking.
- Cooking at slightly lower temperatures.
- Cooking from a cold start so there is no need to preheat the oven – this is good for casseroles and fruit cakes.
- Good cooking results for cream mixtures, rich pastries and bread but with these foods, preheating the oven for 10 to 15 minutes is required.

Defrosting

- Defrosting uses air that is circulated by the fan.
- You should defrost food before cooking it.
- You can also use the defrost function to raise yeast dough and dry fruit, vegetables and herbs.

Condensation

Condensation fogs the oven door and happens when you are cooking large quantities of food from a cold start. You can minimise condensation by:

- Keeping the amount of water used in cooking to a minimum;
- Making sure that the oven door is firmly closed;
- Cooking casseroles with a lid.

NOTE: If you are using water in cooking, this will turn to steam and may condense outside the oven. This is not a problem or a fault.

Cooking guide

- Select the correct shelf location for food being cooked.
- The grill tray can be used in the oven as a baking dish.
- Make sure dishes will fit into the oven and remove unnecessary trays or dishes before you switch it on.
- Keep edges of baking dishes at least 40mm from the side of the oven. This allows free circulation of heat and ensures even cooking.
- Do not open the oven door more than necessary.
- Do not place foods with a lot of liquid into the oven with other foods. This will cause food to steam and not brown.
- After the oven is turned off it retains the heat for some time. Use this heat to finish custards or to dry bread.
- Do not use a lot of cooking oil when roasting. This will prevent splattering oil on the sides of the oven and the oven door. Polyunsaturated fats can leave residue which is very difficult to remove.
- When cooking things which require a high heat from below (e.g. tarts), place the cooking dish on a scone tray in the desired shelf position.
- For sponges and cakes use aluminium, bright finished or non-stick utensils.

Oven shelf location

Your oven comes with formed “easy clean” runners that allow five positions for shelves. These are numbered from 1 (the lowest shelf position) to 5 (the highest shelf position). See diagram.

To give maximum space above and below the shelves, load them in this way:

- When cooking with 1 shelf, use position 3.
- When cooking with 2 shelves, use positions 2 and 4.

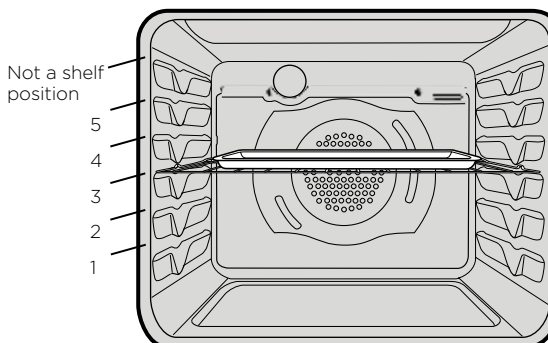

5 shelf positions

OVEN GUIDE

The following is intended as a guide. Cooking variation is natural and to be expected. You should experiment with times, temperatures and recipes to obtain the best results to your own taste. Get to know your oven before making a service call. Where the gas models vary from the electric models, details for gas cooking is shown in brackets. For best results when baking, preheat your oven for 30 minutes.

FOOD	CONVENTIONAL OVEN		FAN FORCED OVEN		TIME IN MINUTES
	TEMPERATURE °C	OVEN SHELF POSITION*	TEMPERATURE °C	OVEN SHELF POSITION*	
Plain or fruit scones	220	2 (3)	210	Any	10 -15
Rolled biscuits	170 (180)	2	150 (170)	Any	10 -15
Spooned biscuits	190	2	180	Any	12 -15
Shortbread biscuits	160	1 or 2	150	Any	30 - 35
Hard individual meringues	110	2	100	Any	90
Soft individual meringues	180	2	165	Any	15 - 20
Pavlova - 6 eggs	110 (120)	1	100	Any	75
Patty cakes	190	2	180	Any	15 - 20
Sponge - 4 eggs	180	2	170	Any	20 - 30
Plain butter cake	180	2	170	Any	25 - 40
Rich fruit cake	140 (150)	2	130	Any	180
Shortcrust cornish pasty#	200 (200/180)	2	180 (180/160)	Any	40 - 45 (10/35)
Shortcrust custard tart	200/180 (220/180)	1(3)	190/170 (200/180)	Any	20 - 30 (10/25)
Cream puffs	210	2	200	Any	25 - 30
Yeast bread	210	1	200	Any	25 - 30
Pizza	220	2	220	Any	15 - 25

* Shelf position is counted from the bottom shelf up. Bottom shelf position is 1.

Turn down temperatures shown.

MEAT/POULTRY/FISH	RECOMMENDED TEMPERATURE °C	MINUTES PER KILOGRAM	
Beef	- Rare	200	35 - 40
	- Medium	200	45 - 50
	- Well done	200	55 - 60
Lamb	- Medium	200	40
	- Well done	200	60
Veal	180	60	
Pork	200	60	
Chicken	180 - 200	45 - 50	
Duck	180 - 200	60 - 70	
Turkey	180	40 - 45 (less than 10kg) 35 - 40 (more than 10kg)	
Fish	180	20	

Roasting Meat

- You can use the grill tray and grill tray insert for roasting meat in the oven.
- Place the meat in the oven and set the temperature between 180°C and 200°C. (It is recommended to wrap your meats in an oven roasting bag or foil to prevent fats and oils from splattering, making it easier to clean your oven.)
- Do not pierce the meat, as this will allow juices to escape.
- When the meat is cooked, take the roast out of the oven, wrap in aluminum foil and leave to stand for about 10 minutes. This will help retain the juices when the meat is carved.

The table shows temperatures and cooking times for different kinds of meat. These may vary depending on the thickness or bone content of the meat.

MEAT	RECOMMENDED TEMPERATURE	MINUTES PER KG
Beef	200°C	Rare 35 - 40
		Medium 45 - 50
		Well done 55 - 60
Lamb	200°C	Medium 40
		Well done 60
Veal	180°C	Well done 60
Pork	200°C	Well done 60

Roasting poultry and fish

- Place the poultry or fish in an oven set at a moderate temperature of 180°C.
- Place a layer of foil over the fish for about three quarters of the cooking time.

The table shows temperatures and cooking times for different kinds of fish and poultry. These may vary depending on the thickness or bone content of the meat.

POULTRY & FISH	RECOMMENDED TEMPERATURE	MINUTES PER KG
Chicken	180°C	45 - 50
Duck	180 - 200°C	60 - 70
Turkey	180°C	40 - 45 (<10kg)
		35 - 40 (>10kg)
Fish	180°C	20

GET TO KNOW YOUR NEW OVEN WITH THIS 'SIMPLE TEST CAKE'

Although we strive for a perfect performing oven, it's possible that there will be some variation in colour when baking. Therefore, we suggest this simple, easy and delicious to make Simple Test Cake, it can help you understand your new oven. All ovens do sometimes have hot or cold spots, therefore it is important to judge with your eye as you may require to rotate during baking.

125g butter, softened to room temperature

1 cup caster sugar

1 teaspoon pure vanilla essence

4 large eggs

2 cups self-raising flour

Pinch of salt

4 tablespoons (80ml) full-cream milk

Method:

1. Butter base and sides of two, 20cm straight-sided round or square cake pans. Then line the base with grease proof or baking paper.
2. Preheat oven to moderate 180°C (170°C fan forced) and ensure oven shelf is in the centre position of oven.
3. Cream softened butter and sugar until light in colour.
4. Add vanilla essence.
5. Then eggs one at a time, beating well after each addition.
6. Sift flour and salt into the mixture and beat until well combined.
7. Add milk and beat or stir to combine.
8. Spoon mixture equally between prepared cake pans.
9. Bake in preheated oven, middle shelf for about 25 to 35 minutes or until when tested with a fine cake skewer it comes out clean or the edges of the cakes have come away slightly from the sides of the cake pans.
10. Remove from oven to wire cake rack and rest for 5 minutes before removing from cake pans. Cool completely.

To serve: Sandwich together with your favourite jam or conserve, and dust top with pure icing sugar.

NOTE: If desired, substitute butter for either margarine or olive oil spread.

Recipe is based on the Australian standard metric 250ml cup and 20ml tablespoon sets.

DEALING WITH COOKING PROBLEMS

PROBLEM	CAUSES	WHAT TO DO
Uneven cooking	Incorrect shelf position	Select shelf that puts food in centre of oven
	Oven tray too large	Try other trays or dishes
	Trays not in centre	Put trays in centre
	Air flow in oven uneven	Rotate food during cooking
	Grill tray affecting thermostat	Remove grill tray from oven on bake modes
Baked products too brown on top	Oven not preheated	Preheat the oven
	Baking tins too large for recipe	Use correct size tins
	Baking tins not evenly spaced	Stagger baking tins at least 3cm between tins and the oven walls
	Products not evenly sized or spaced on trays	Make into same size and shape and spread evenly over trays
	Baking temperature too high	Lower the temperature
Baked products too brown on bottom	Baking tins too large for recipe	Use correct size tins
	Baking tins are dark metal or glass	Change to shiny, light tins or lower the temperature by 10°C
	Food too low in oven	Cook one shelf higher
	Oven door opened too frequently during baking	Don't open the oven door until at least half the cooking time has passed
	Baking temperature too high	Lower the temperature
	Grill tray affecting thermostat	Remove grill tray from oven on bake modes
Cakes have a cracked thick crust	Baking temperature too high	Lower the temperature
	Food too low in oven	Cook one shelf higher
	Cake batter over mixed	Mix just long enough to combine the ingredients
	Baking tin too deep	Check size of tin and use recommended size
	Baking tins dark	Change to shiny light tins
Baked products are pale, flat and undercooked	Baking temperature too low	Raise the temperature
	Food too low in oven	Cook one shelf higher
	Baking time too short	Increase cooking time
	Incorrect baking tin size	Use correct size tin
Cakes fallen in centre	Baking temperature too low	Raise the temperature
	Baking time too short	Increase cooking time
	Proportions of ingredients incorrect for recipe	Check recipe
	Opening door too early during baking	Do not open door until the last quarter of cooking time
Roast meat and potatoes not brown in fan oven	Poor hot air circulation	Elevate food onto a rack to allow air circulation
	Grill tray affecting thermostat	Remove grill tray from oven on bake modes
Juices running out of meat		Do not pierce meat with fork, turn with tongs
Grilled meats overcooked on outside & raw in the centre		Grill at lower insert position (Grill in oven models only)
Grilled chops & steaks curling		Cut into fat every 2cm (¾")

CLEANING THE COOKER

Ovens and hotplates are made from steel and enamel. Do not use abrasives and harsh scourers as they may scratch the surface.

Enamel

- Keep enamel clean by wiping it with a soft cloth dipped in warm soapy water.
- Rub difficult stains with a nylon scourer or cream powder cleanser.
- DO NOT use abrasive cleaners, powder cleaners, steel wool or wax polishes.
- If you use an oven cleaner, follow the instructions on the product carefully.

Stainless Steel

- All grades of stainless steel can stain, discolour or become greasy. Clean the cooker regularly, using the procedures outlined below, to maintain the function and appearance of your appliance.
- Care must be taken when wiping exposed stainless steel edges as they can be sharp.
- The front frame around the oven can be cleaned with stainless steel cleaners if it comes soiled or discoloured.
- A suitable cleaner can be purchased from Electrolux Customer Care Centres.
- Always clean the stainless steel in the direction of the grain. Going against the grain may scratch the surface.

Oven Shelves

- Chrome shelves: use detergent and hot water. If very dirty use a non-abrasive nylon scourer.

Oven – Grill Dish and Insert

- After every use and while still warm, wash pan and grill with warm soapy water and a suitable oven cleaner. Rinse and dry before replacing in position.

Oven

- Use detergent, warm water (and household cloudy ammonia if necessary) and a soft cloth. Dry thoroughly.
- Remove shelves when the cleaning oven.
- If there is a build-up of grease use a suitable oven cleaner, following the instructions on the cleaning product carefully. Heat oven to 110°C and turn oven off when 110°C is reached. Leave over-night. The fumes will loosen stubborn grease and stains. Remove bowl, wash with hot, soapy water and dry well before closing oven door again. Ensure oven is thoroughly rinsed and dried before subsequent use.



CAUTION

DO NOT remove the oven door.

Glass

- Glass surfaces on doors and control panels are best cleaned immediately after soiling.
- A damp cloth may help remove baked on food deposits.
- Oven cleaners can be used to remove stubborn marks and stains.



WARNING

The door glass on this appliance is made from tough durable material that withstands heating and cooling without breaking. However it must be remembered that it is glass, it may break. Treat it accordingly!

Should you have any questions about the glass in your appliance, please contact the customer care centre by calling 1300 363 640. Do not use harsh cleaners or sharp metal scrapers to clean the oven door since they can scratch the surface, which may result in shattering of the glass.

Ceramic Hotplate

- Remove all spilt food and fat with the supplied razor blade scraper, while the ceramic glass is still warm but not hot. Wipe clean with dishwashing detergent on a damp cloth.
- If aluminium foil, plastic items or high sugar content foods are allowed to melt on the ceramic glass, clean immediately with the supplied razor blade scraper before the surface has cooled down, otherwise pitting of the surface can occur.

NOTE: Items with high sugar content not only include jam and fruit, but also vegetables such as peas, tomatoes and carrots.

- When the ceramic glass is cool, apply a suitable ceramic glass cleaner.
- It is important to follow the cleaner manufacturer's instructions. Remove any cleaning residue from the surface as staining of the cooktop may occur.
- Do not use abrasive sponges or scourers, as they may scratch the surface.
- Any pitting, staining, scratches or other surface deterioration is excluded from the warranty.
- All stains/water marks can be removed by vigorous cleaning, using a ceramic glass cleaner.
- Sometimes surface stains appear to be 'bubble' marks under the ceramic glass. These can be cleaned with a razor blade scraper and ceramic cleaner.

CLEANING THE COOKER (CONTINUED)



WARNING

Grill

- Always keep the grill tray and grill tray insert clean, as any fat deposits may catch fire.

Gas Burners

- Flame port blockages should be removed with a small metal cake skewer or nylon brush.
- Clean dirty spark plugs very gently with a nylon scourer. Do not use steel wool. Do not bend spark plug as it may break.
- If the caps, crowns and cups are heavily soiled, use a non-abrasive cleaning compound.
- Do not clean these parts with abrasive or caustic type cleaners, or clean in a dishwasher as they will be damaged.

CLEANING YOUR OVEN ACCESSORIES

Cleaning the grill

Grill tray and grill pan

- Wash the grill tray and grill pan in hot soapy water.



WARNING

Always keep the grill pan clean as any fat left in it may catch fire.

Grill Compartment

- Clean the grill compartment with hot soapy water.
- If stronger action is needed use a non-abrasive oven cleaner applied with a nylon scourer.

Removing and replacing the oven light



WARNING

Make sure the appliance is turned off before you remove or replace parts, to avoid the possibility of electric shock.

Turn oven light glass
anti-clockwise to
remove it for globe
replacement

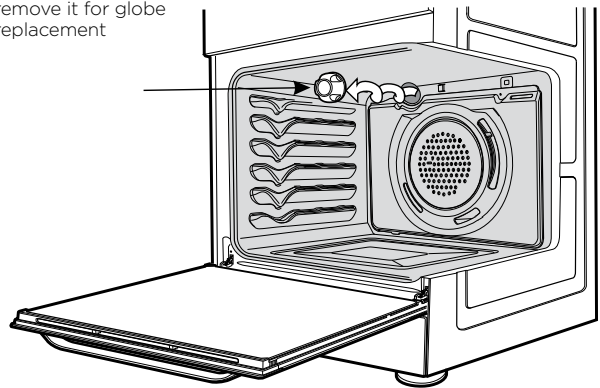

A special high temperature resistant globe should be used. This can be purchased from the Electrolux Customer Care Centre. Light globes are not covered by warranty.

CLEANING AND CARING FOR THE OVEN

Cleaning the oven door

Cool air circulates through the door to lower the surface temperature on the outside of the oven door.



CAUTION

- Do not remove the outer oven door. This product has a removable inner glass insert for ease of cleaning.

To remove the inner door glass for cleaning

- Open the door fully to access the hinges then rotate the “stirrups” on both hinges fully towards the door.

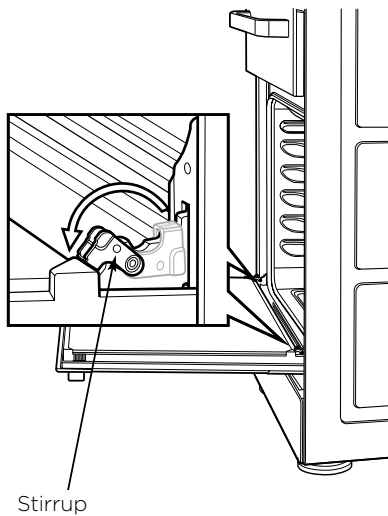

- Slowly close the door until it stops against the ‘stirrups’.

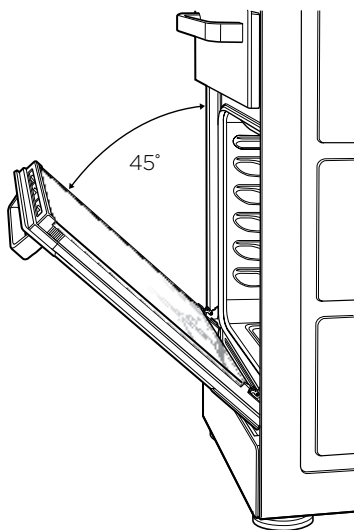

- To remove the top trim, press the ribbed release clips at each end and lift top trim away from the door.

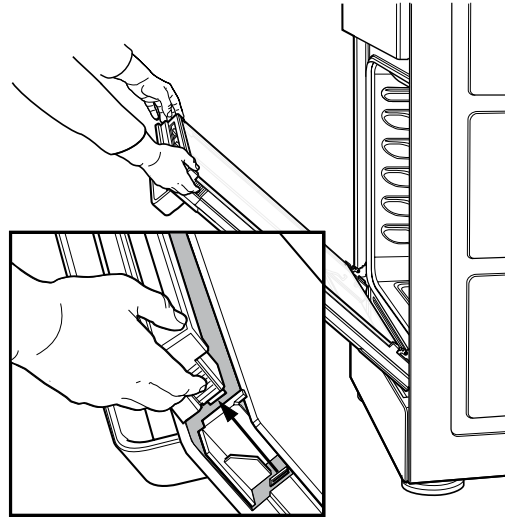

- Using both hands, gently remove the inner glass by sliding out and lifting away from the door.

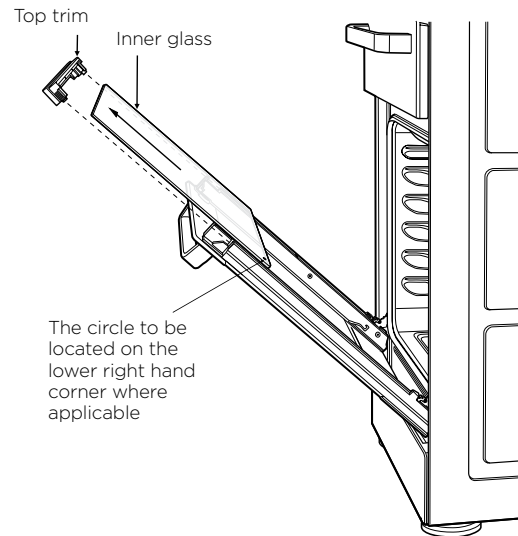

- Hand wash only with a soft cloth and warm soapy water. When dry, polish with a soft cloth and ensure the glass is dry before re-assembly.
- Wipe inner and outer glass gently with detergent and warm water.
- Wipe clean and dry thoroughly.

CLEANING AND CARING FOR THE OVEN

Re-assembling the oven door inner glass

- When replacing the door inner glass, make sure the circle is positioned as shown in the image (where applicable).
- Replace the top trim ensuring the clips snap back into position.
- Fully open the door, rotate the stirrups back to their original position and close the door.



WARNING

- DO NOT use the oven without the inner glass fitted.
- DO NOT use harsh abrasives on glass as this may damage the glass.
- DO NOT place glass in dishwasher.

Safety warnings about cleaning



WARNING

- ALWAYS make sure that the cooker is turned off before cleaning.



CAUTION

- ALWAYS clean cooker immediately after use.
- DO NOT use steam cleaners. These may cause moisture build-up, especially in the glass door.
- DO NOT use caustic based cleaners or harsh abrasives, these will damage your oven.

Door glass

- DO NOT use harsh abrasive cleaners or sharp metal scrapers to clean glass since they can scratch the surface, which may result in shattering of the glass.

SOLVING PROBLEMS

Faults

If there is a problem with the oven and/or grill, please:

- Check the points listed below before calling for service. It may be possible to avoid a call by fixing the problem yourself – and so continue cooking.
- For cooking problems, refer to “Dealing with cooking problems”.

NOTE: We may charge for service even in the guarantee period if your problem is due to the causes listed below.

Further information

If you need more information, service, replacement parts or have a warranty enquiry, please contact the Customer Care Centre:

- Australia – 1300 363 640, 8.00am - 5.00pm EST Monday - Friday
- New Zealand – 0800 436 248, 8.00am - 5.00pm EST Monday - Friday

Please have the following information ready: Model, Model Number and Serial Number. This is shown on the data plate which is visible when the oven door is open.

PROBLEM	POSSIBLE CAUSES	WHAT TO DO
Oven or grill not working	Power not turned on	Switch on electricity
	Household fuse blown	Check fuses
	Controls incorrectly set	Reset controls
	Circuit breaker tripped	Check circuit breaker
	Clock not set	Set time of day on timer
	Gas is off	Check gas is supplied to the cooker
<i>NOTE: If the household fuse continues to blow, call the Electrolux Customer Care Centre.</i>		
Oven not heating enough	Foil or trays on bottom of oven	Remove foil or trays
Light and fans on continuously	Timer not in manual mode	Set timer to manual mode
Oven not working	Timer not in manual mode	Set timer to manual mode
	Household fuse blown	Check fuses
<i>NOTE: If the household fuse continues to blow, call the Electrolux Customer Care Centre.</i>		
Oven light not working	Household fuse blown	Check fuses
	Circuit breaker tripped	Check circuit breaker
	Lamp blown or loose in socket	Replace or tighten lamp
<i>NOTE: If the household fuse continues to blow, call the Electrolux Customer Care Centre.</i>		
Cooker smoking when first used	Protective oils being removed	Turn grill on high for 30 mins and then the oven on 220°C for 1 hour
Too much condensation building up when baking	Too much water used when cooking	Reduce amount of water
		Leave oven door open after cooking
Smells when first using oven	Protective oils being removed	This is normal
120 minute timer ring not audible	Timer not wound sufficiently	Turn timer knob past 20 minutes then turn back to required number of minutes
Gas hotplates not working	Power not turned on at appliance	Switch on electricity
	Household fuse has blown or power supply is turned off	Check fuses
	Gas is off	Check gas is supplied to the cooker
	Burner parts or spark plugs are wet or dirty	Clean and dry burners or spark plugs
Timer flashing	Power failure or interruption	Reset time of day
Stains appear to be under ceramic glass	These marks are on the surface of the ceramic glass.	Clean marks off with a razor blade scraper and ceramic glass cleaner.
The oven seal is loose	The oven seal is attached at each corner. It may seem like a loose fit, but when the oven door is closed it will function correctly.	This is normal

NOTE: In the event of a power failure the gas burners may still be lit with a handheld igniter and used. Take care to avoid letting unburned gas flow for more than 5 seconds when attempting to light the burner.

INSTALLATION

Removing the oven door

(To be done by qualified personnel only)

1. With door fully open, rotate the two stirrups to its rest position.

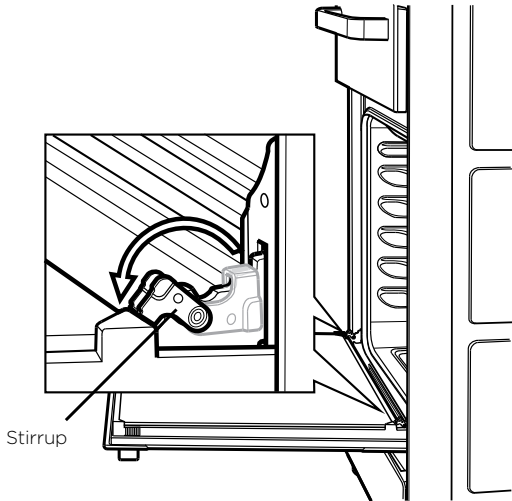

2. Close the door until it stops against the stirrups.

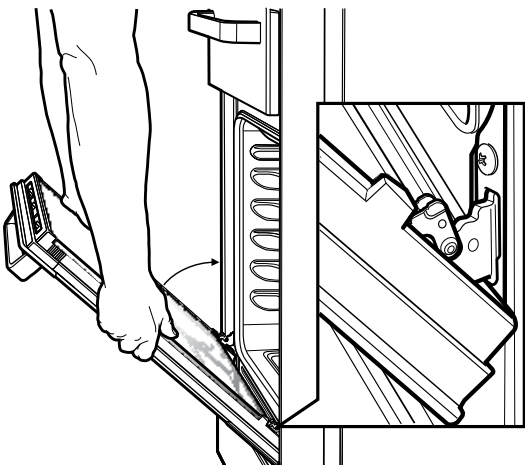

3. Close the door further.

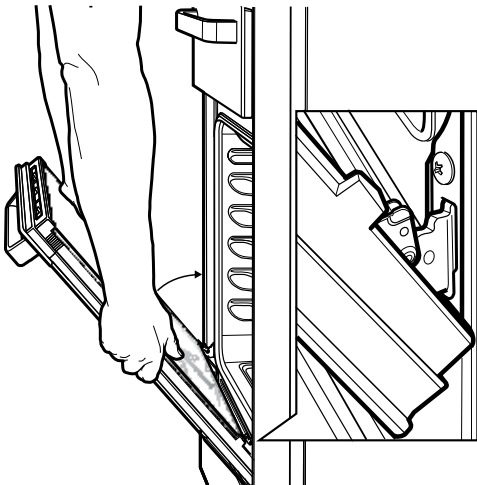

4. Lift the door slightly and evenly while continuing to slowly close the door.

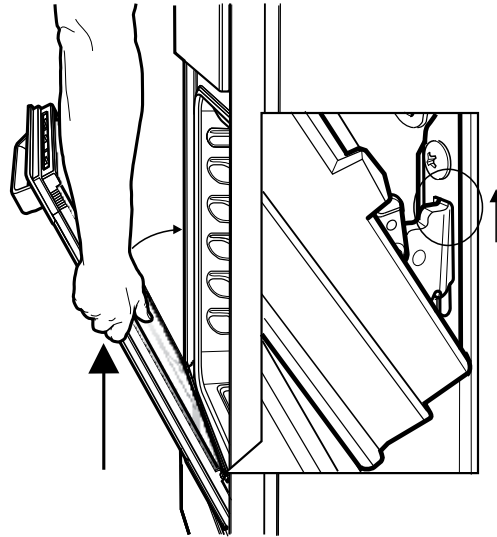

5. Remove the door by lowering gently and pull away from the frame of the oven. Care should be taken not to damage kick panel and other parts of the cooker.

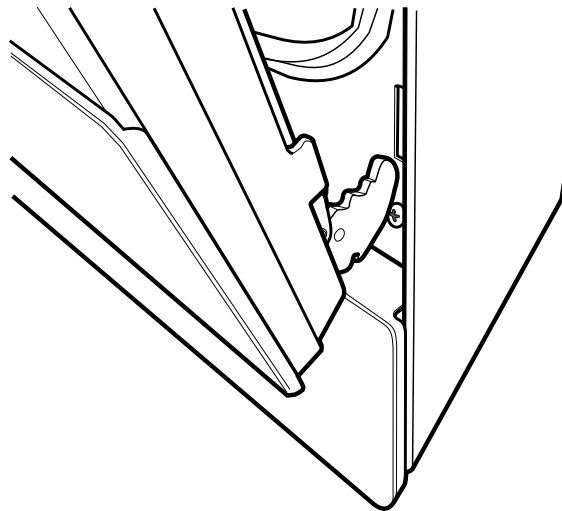

Replacing the oven door

(To be done by qualified personnel only)

1. Hold door with both hands.
2. Locate both hinges into the frame slots at the same time.

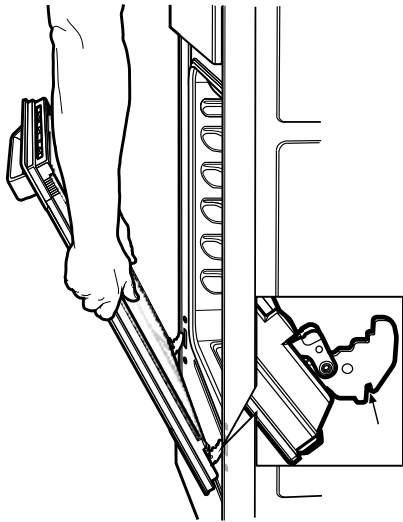

3. Ensure that the location notch drops into frame slot. Care should be taken not to damage other parts of the cooker.

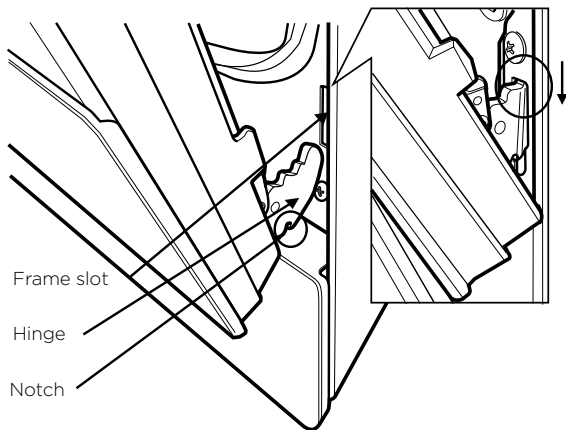

4. Open door fully and rotate stirrups away from you, and back to their original position.

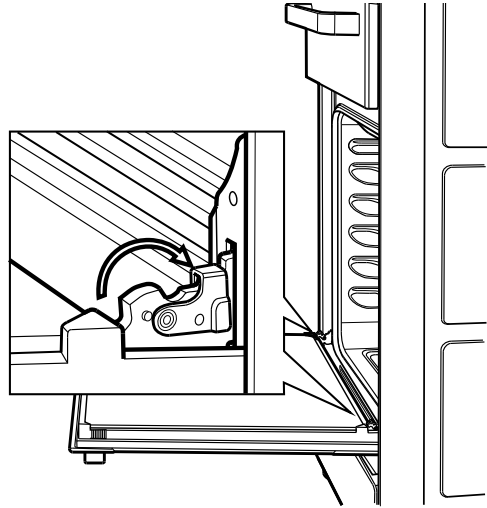

5. Close the door fully.

INSTALLING THE APPLIANCE

(600mm wide product)

Cabinet requirements

This appliance has been designed to 'slot-in' to a 600mm wide gap built-in standard kitchen cabinets. As such the appliance can be installed to suit the height of the benches

This allows the cooker to integrate well into contemporary kitchens. The cooker may also be installed at the end of a line of benches or with a free space on either side.

- Electric hob models must not be installed in a corner; they must be installed at least 100mm from the side wall. Gas hob models must be installed with a minimum clearance of 100mm to side walls made of unprotected combustible materials.
- For gas models refer to section 6.10.1 in AS/NZS 5601.1 for all relevant clearances.



WARNING

This appliance has been tested and approved to the relevant Australian Standards. It is designed to cook food, it will get hot. Cabinet materials must be capable of withstanding 85°C. Installation into lower temperature tolerant cabinetry (e.g. vinyl coated) may result in deterioration of the low temperature coating by discolour or bubbling.

Electrolux Home Products cannot accept responsibility for damage caused by installation into low temperature tolerant cabinets.

Installation and service warning



WARNING

- Only an authorised person must install and service this appliance (Certificate of Compliance to be retained).
- In order to avoid a hazard, the installation instructions MUST be followed.
- In order to avoid the appliance tipping, the anti-tilt plate MUST be installed.
- Appliances requiring connection to 230 - 240V MUST be earthed.
- An authorised person should inspect this appliance every 5 years.
- This appliance must NOT be installed on a base, box or in a closed cupboard.
- If the electrical supply cord is damaged, a qualified person MUST replace the cord to avoid a hazard or void your warranty.
- The unit must be pushed up against the wall on installation. On gas units check that the gas hose, if used, has not been kinked during installation.

Recommended cabinet design

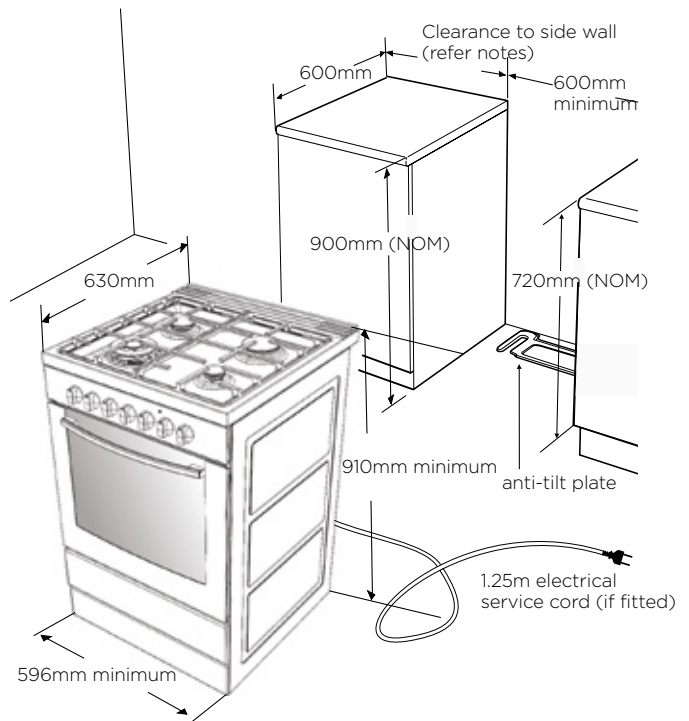

Preparing for installation

1. Check that the required services are correctly positioned (see electrical and gas services requirements section and cabinet requirements section).
2. Ensure that cabinetry has correct details (see cabinet requirements section).
3. Unpack the cooker.
4. Remove the foam pack containing accessories.
5. Remove the internal pack from the oven and position shelf supports and grill trays.
6. Remove the 2 screws for the splashback from the rear panel, and fit it to the unit with the same screws.

Fitting the anti-tilt plate & stabilising bolt

Cooker Stability

NOTE: To ensure cooker stability, both the anti-tilt plate and stability bolt MUST be installed on all cookers (electric and gas).

Installation Sequence

1. The cooker is delivered with the anti-tilt plate. Locate the anti-tilt plate against the rear wall. If locating between 2 cupboards, then fit the plate in the centre of the space. If locating the cooker at the end of a cupboard, then position the side of the plate 48mm from the cupboard.

NOTE: If cooker cannot be located against rear wall, move anti-tilt plate forward to suit.

2. Securely fix the anti-tilt plate to the floor with appropriate fasteners.
3. Slide the cooker back into the anti-tilt plate so that rear cover rests against the rear wall.
Then check the height and level of the cooker.
If required, pull the cooker back out and adjust the levelling feet as required.
4. Cut the cable tie from the stability bolt.
5. Rotate the stability bolt 180 clockwise until it is pointing to the left like the picture below.
6. The stability bolt should now be able to drop to the floor.
7. Mark the position for the stability bolt on the floor.
8. Pull the cooker out and drill the bolt hole, using a 6.5mm masonry or wood drill. Minimum 30mm deep for concrete.
9. Reposition the cooker back into place, then fit the stability bolt into the drilled hole.
10. Connect gas and electricity supply (refer to pages following).
11. Fit the kick panel onto the cooker.

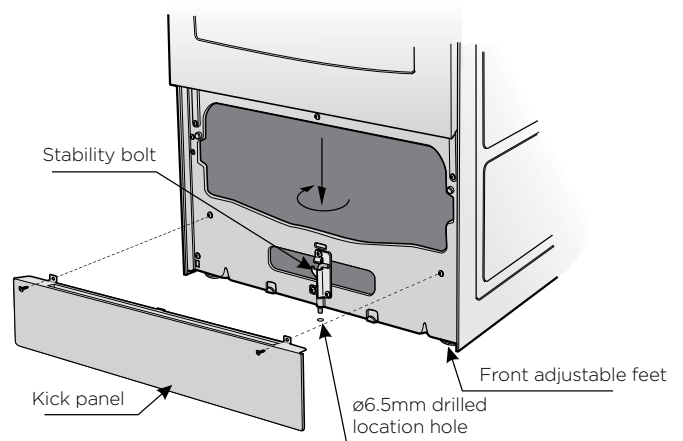
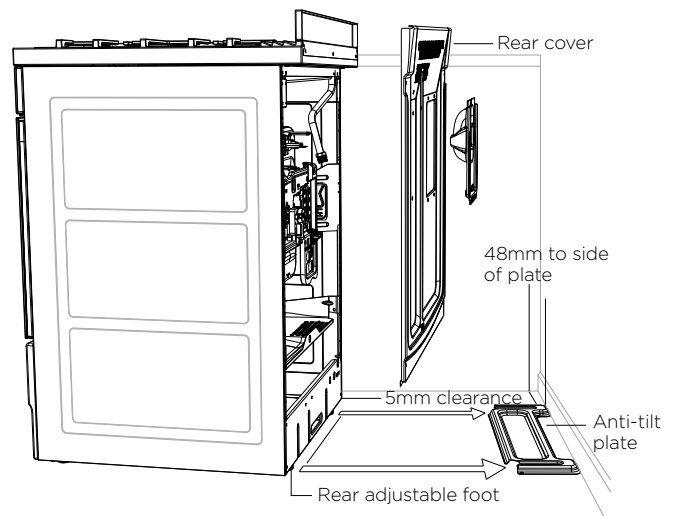

Installing splashback

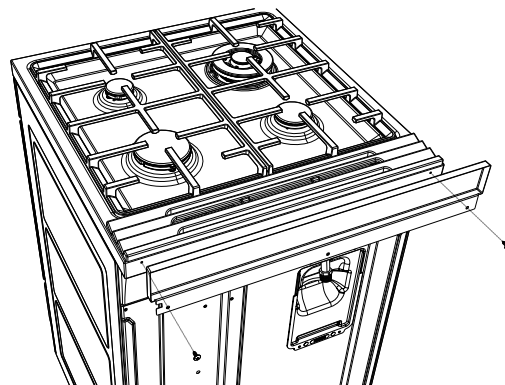

Fit splashback to rear of hob with the two screws provided.

INSTALLING THE APPLIANCE (540mm wide product)

Cabinet Requirements

This appliance has been designed to 'slot-in' to a 540mm wide gap built-in standard kitchen cabinets. As such the appliance can be installed to suit the height and depth of benches and behind the kick rail of the cabinets. This allows the cooker to integrate well into contemporary kitchens. The cooker may also be installed at the end of a line of benches or with a free space on either side.

- Electric hob models must not be installed in a corner; they must be installed at least 100mm from the side wall. Gas hob models must be installed with a minimum clearance of 100mm to side walls made of unprotected combustible materials.
- For gas models refer to section 6.10.1 in AS/NZS 5601.1 for all relevant clearances.

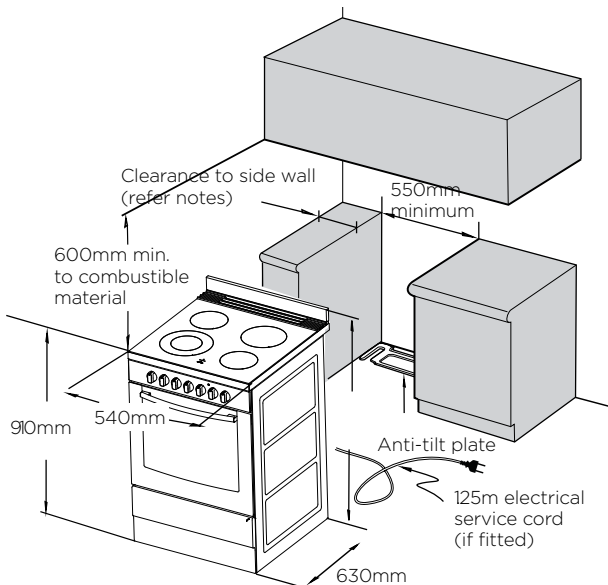

WARNING

In order to avoid accidental tipping of the appliance (for example, by a child climbing onto the open oven door), the anti-tilt plate and stabilising bolt **MUST** be installed.

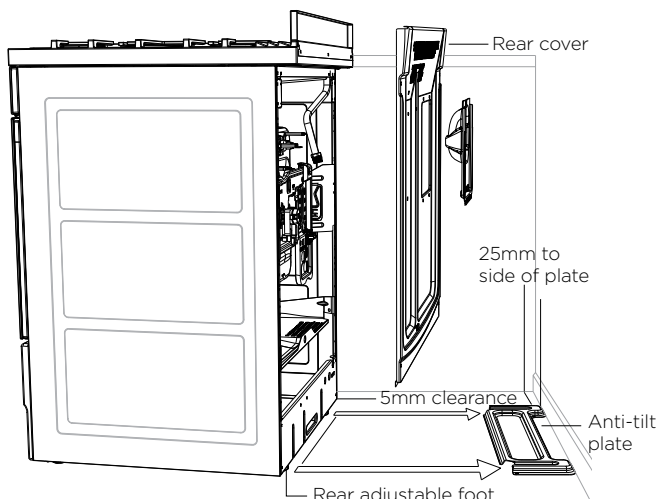

Position anti-tilt plate to the rear wall and 25mm from side of cupboard. Securely fix anti-tilt plate to the floor with fasteners. Adjust levelling feet on cooker as required.

Stabilising bolt

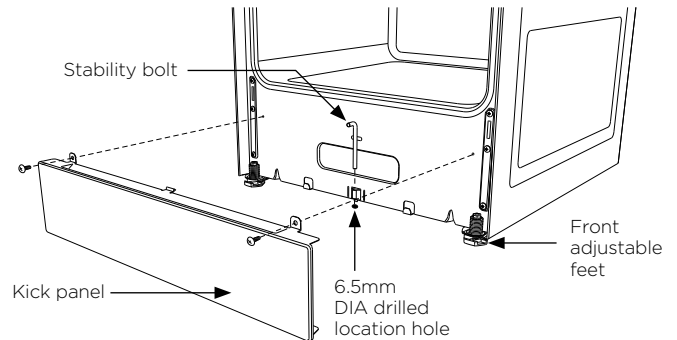

Remove oven door - to be done by qualified personnel only. (Refer to procedure).

2. Remove screws from kick panel. To remove kick panel lift kick panel upwards to release the two location tabs from the holes in the bottom of the panel.
3. Position cooker into the anti-tilt plate and then mark the position for the stability bolt hole on the floor.
4. Pull cooker out and drill the bolt hole, using a 6.5mm masonry or wood drill bit. The bolt hole needs to be a minimum of 30mm deep when fixing the oven to concrete.
5. Reposition cooker back into place and fit the stability bolt through the slot and into the drilled hole.
6. If the cooker is placed on a base, measures must be taken to prevent the appliance slipping from the base.

WARNING

For your safety this cooker is designed to be moved out of position by a qualified person only.

Installing Splashback

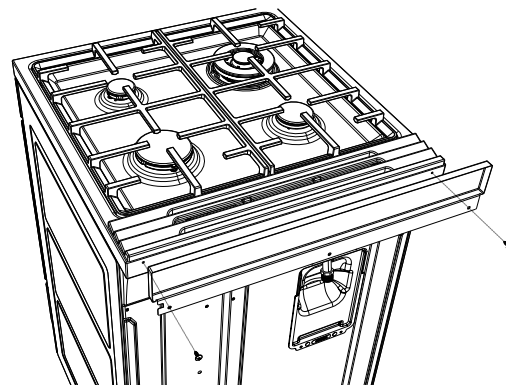

Fit splashback to rear of hob with the two screws provided.

WIRING REQUIREMENTS

The cooker MUST be installed in compliance with:

- Wiring connections in AS/NZS 3000 Wiring Rules
- Local regulations, municipal building codes and other statutory regulations
- For New Zealand Only:
The cooking range must be connected to the supply by a supply cord fitted with the appropriately rated plug that is compatible with the socket-outlet fitted to the final sub-circuit in the fixed wiring that is intended to supply this cooking range.

Data plate	gives information about rating
	is located behind the bottom of the oven door

- A functional switch MUST be provided near the appliance in an accessible position (AS/NZS 3000 - Clause 4.7.1).
- Wiring MUST be protected against mechanical failure (AS/NZS 3000 - Clause 3.9).
- Disconnection in the fixed wiring must occur in accordance with the AS/NZS3000 wiring rules.
- The cooker MUST be properly earthed.
- This range must be connected with cable of 75°C rating minimum.
- This product has passed the insulation resistance test after manufacture. If the resistance reading is low at installation, it is probably caused by moisture from the atmosphere being absorbed by the elements after the range has been produced. (Pass at 0.01MΩ AS/NZS 3000 Wiring Rules Clause 8.3.6.2).

NOTE: When connections are made to a multi-phase 230/240V supply, the bridge piece MUST be removed from between the active connections.



TIPS AND INFORMATION

Before you cook in your new oven it is important that the protective oils used in the manufacture of the product be removed.

- Make sure that the room is well ventilated (to allow smoke to escape).
- New appliances can have an odour during first use. It is recommended to 'run in' the oven before cooking for the first time Operate the oven(s), empty, at a temperature of 180°C for approximately 30 minutes. For appliances with a separate grill, run the grill on maximum for 15 minutes WITH GRILL DOOR OPEN Please ensure that the room is well ventilated during this process.

MODEL	TOTAL WATTAGE (KW)	TOTAL CURRENT (AMPS)	CABLE SECTION (MM2)	MINIMUM TEMP. RATING (°C)
WFE642	8.7	36.3	2.5	75
WFE647	10.5	43.8	4.0	75
WFE547	10.5	43.8	4.0	75

CONNECTING TO SERVICES AND COMMISSIONING

This appliance must be installed by an authorised person, according to all codes and regulations of:

- Electrical supply authorities.
- Building regulations.
- Local government and council authorities.
- AS/NZS 5601.1 (particular attention to clause 6.10.1 and figure 6.3 on page 97, and clause 6.10.1.11).
- AS/NZS 3000 (particular attention to clause 4.7.1 and clause 3.9).

Electrical supply connection

- WFE619 and WFE517 models are fitted with a 20-Amp service cord.
- WFE616 and WFG617 models are fitted with a 10-Amp service cord.

Hard wiring detail (WFE547, WFE642 and WFE647 models only)

1. Remove terminal cover plate from rear panel of appliance.
2. Fit wires through hole in cover plate and make connections to terminals.
3. Engage wires into plastic clip. Secure plastic clip with two long silver screws (supplied in separate bag).
4. Replace cover plate onto rear panel.

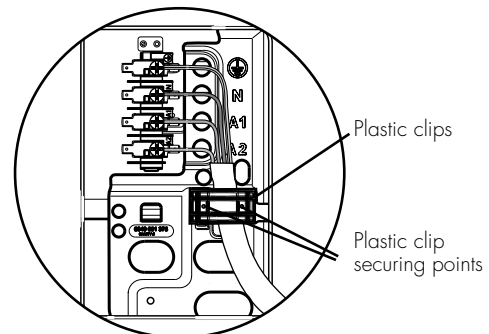

RATED POWER INPUT

MODEL	TOTAL KW	A1 KW	A2 KW
WFE547	10.5	4.1	6.4
WFE642	8.7	2.3	6.4
WFE647	10.5	4.1	6.4

CONNECTIONS

Wiring connection for gas cooker

To allow for disconnection of the appliance after installation, the plug must be accessible after installation.

If the supply cord is damaged, it must be replaced by the manufacturer, its service agent or similarly qualified persons in order to avoid a hazard.

Installing the gas cooker gas connection

Read these points before connecting to the gas supply:

- The cooker inlet connection point has a ½" BSP external thread. See diagram below.
- An NG regulator or a LPG test point fitting is supplied.
- It is recommended to fit the regulator or test point fitting to the appliance connection point, then fit either hard piping or a high level flexible connection (AS/NZS 5601.1 clauses 5.9 and 6.10.1.9) which is then attached to the consumer hard piping.
- Ensure installation allows withdrawal of appliance.

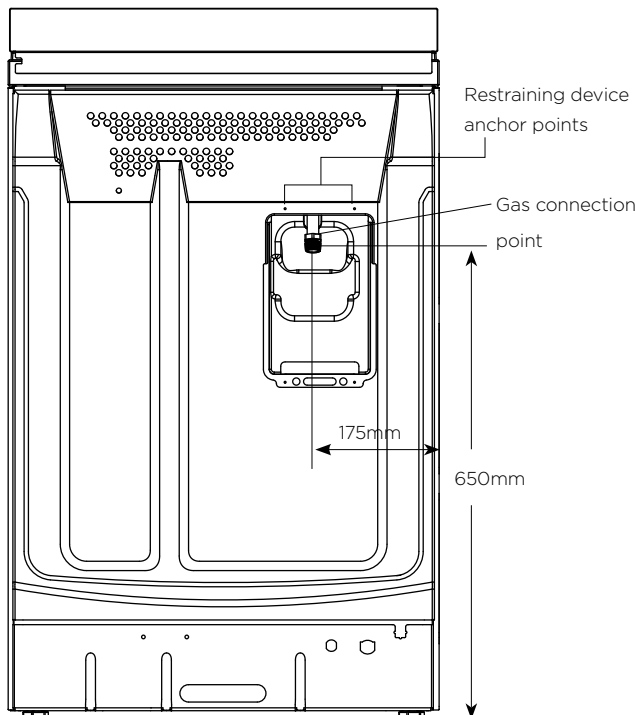

Operation on universal LPG/propane

1. The appliance inlet fitting provided MUST be orientated so that the pressure nipple is accessible.
2. The inlet fitting has ½" BSP internal thread at the inlet and outlet.

Operation on SNG (WFG617 models only)

- If the cooker is to be used with SNG, then the grill burner MUST be modified by the replacement of the shutter, which fits into the throat of the grill burner.
- A conversion kit can be obtained by contacting the Customer Care Centre.

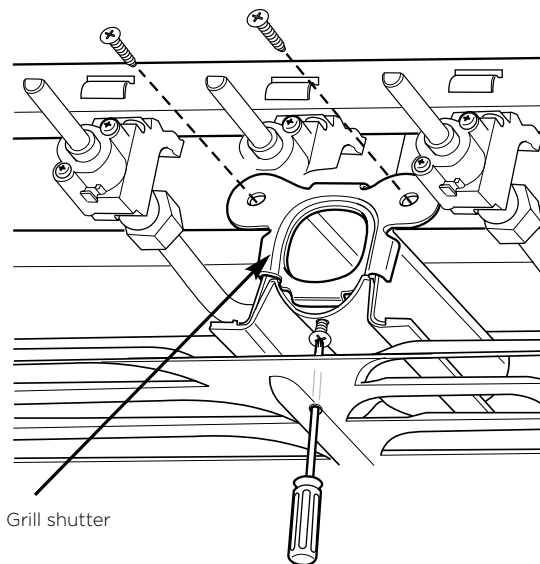
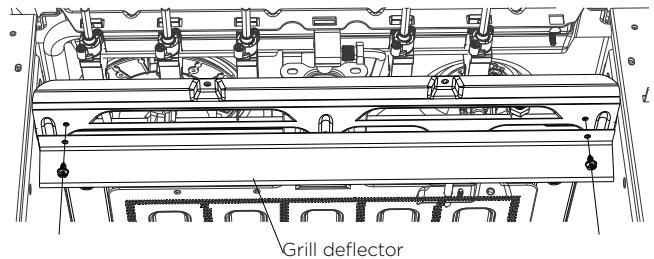

WARNING

Disconnect electric power before removing control panel.

1. Remove the control panel.
2. Remove the 2 screws from grill deflector (refer to diagram above)
3. Remove the existing NG shutter securing screw (refer to diagram above) and slide upwards to disengage from grill burner.
4. Slide the SNG shutter into position and secure with screws.

Testing the gas cooker

WARNING

You MUST test the cooker after installation, before you hand it over to the customer.

You MUST have a manometer and a connecting tube.

CONNECTIONS

Gas requirements

This appliance must be installed by an authorised person, according to all codes and regulations of:

- AS/NZS 5601.1 (particular attention to clause 6.10.1 and figure 6.3 on page 97, and clause 6.10.1.1)

The cookers come in two gas types: Natural gas and Universal LPG. Before installation check that the cooker is suitable for the gas supply. To do this check the gas type on the carton sticker or on the data plate behind the bottom of the oven door. The following table shows the supply and operating pressures for various gas supplies.

GAS TYPE	NATURAL GAS	UNIVERSAL LPG
Supply pressure at inlet to appliance regulator (if fitted)	113 kPa Minimum	2.75* kPa
Operating pressure at appliance test point for WFG617	1.00 kPa	2.75 kPa
Operating pressure at appliance test point for WFE517, WFE616, WFE619	1.00 kPa	2.60 kPa

**Some models do not require an appliance regulator for LPG operation, in which case the supply pressure and operating pressure are the same. In such cases the supply pressure is adjusted at a regulator in the consumer piping, typically located at the cylinder.*

The following table shows the injector sizes for each burner.

INJECTOR ORIFICE	NATURAL GAS	UNIVERSAL LPG
Low heat burner	1.00 mm	0.55 mm
Medium heat burner	1.35 mm	0.70 mm
High heat burner	1.60 mm	0.90 mm
Intense heat wok burner	1.75 mm	1.00 mm
Oven - main injector	1.60 mm	0.82 mm
Grill	1.50mm	0.82mm
Oven - bypass screw	0.73mm	0.45mm

Checking pipe size

To work out a suitable pipe size for connection use:

- The information in this table.

GAS TYPE	NATURAL GAS	UNIVERSAL LPG
Hourly gas consumption for WFG617	63.3MJ/h	52.4MJ/h
Hourly gas consumption for WFE616, WFE619	40.4MJ/h	34.4MJ/h
Hourly gas consumption for WFE517	37.3 MJ/h	30.2MJ/h

- Information about the length of the run, number of elbows, tees and bends, the available service pressure and the supply requirements.

NOTE: AS/NZS 5601.1 will help you with this matter.

LPG CONVERSION DONG YANG – IMPORTANT (MODELS WFE517, WFE616 AND WFE619 ONLY)

This appliance is fitted with Natural Gas burner injectors. Please follow the procedure below if a conversion to suit UNIVERSAL LPG is required.

The conversion kit contains 5 injectors and 1 LPG sticker.

1. Remove the hotplate burners to access the hotplate injectors. Replace the factory fitted NG injectors with the appropriate injectors, as supplied.
2. Unscrew the hex nut from the regulator. The hex nut, brass washer and nylon insert will disengage as an assembly.
3. Unclip the nylon insert from the nut assembly by rotating the insert 1/4 turn, and pulling it free.
4. Turn over the insert, and clip back into position.
5. Refit the hex nut assembly to the regulator ensuring that it is fully screwed down. The regulator is now set for connection to LPG.
6. Turn on the gas supply and at each new connection check for leaks using soapy water: each hotplate valve should be turned on, one at a time, and the injector hole blocked off for several seconds.
7. The operation of the regulator can be confirmed by connecting a manometer to the pressure test point located on the side of the regulator body adjacent to the outlet. With the appliance operating check the outlet pressure:
 - When all burners of the appliance are operating at maximum,
 - When the smallest burner of the appliance is operating at minimum.

Under these conditions the outlet pressure should not vary from the nominal outlet pressure of 2.60kPa by more than $\pm 0.52\text{kPa}$.

8. If the regulator appears to not be performing satisfactorily then check the following points:
 - If the outlet pressure is consistently too low then the inlet pressure may be too low and adjustment of an upstream regulator may be needed, or an upstream regulator or valve with insufficient flow capacity may be present in the gas supply line. If this is suspected then it may be necessary to repeat the checks whilst measuring both the inlet and outlet pressure to determine if the inlet pressure is in the range 2.75 – 7.00kPa.
 - Check that the insert has been fitted correctly.
 - Check that the turret screw is fully screwed down.
 - Check that the regulator has been fitted to the gas supply line in the correct orientation, the arrow on the base of the body indicates the direction of gas flow.

Once these checks have been completed, if the regulator still fails to perform in a satisfactory manner it should be replaced.

9. One by one, turn the knobs to minimum and screw in the bypass screw (accessible when the knob is removed) until a small stable flame results. Turn the knob to maximum and then back to minimum to ensure that the correct minimum flame is maintained.
10. Attach the LPG sticker to the cooker, near the gas supply inlet. Cover the Natural Gas label that is factory fitted.

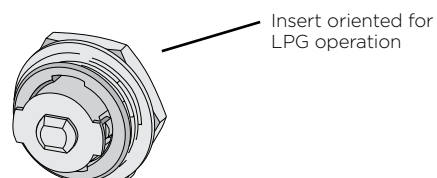
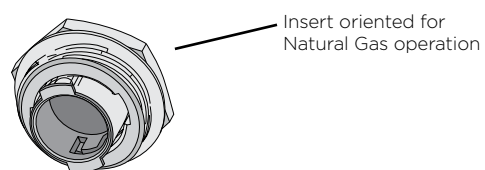
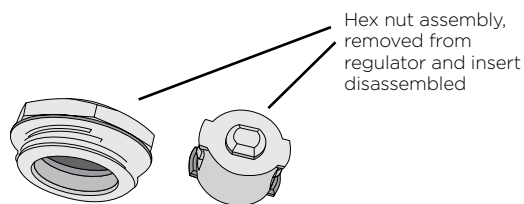
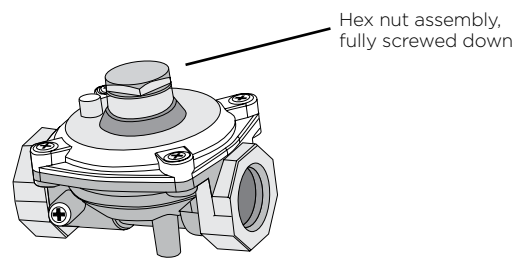

LPG CONVERSION CHANT – IMPORTANT (MODELS WFE517, WFE616 AND WFE619 ONLY)

This appliance is supplied set up for Natural Gas usage. A conversion kit is included with the product for Universal LPG usage. The conversion kit contains 5 injectors and 1 LPG sticker.

Please follow the procedure below if a conversion to suit UNIVERSAL LPG is required:

1. Remove the hotplate trivets, burner caps and burner crowns to access the hotplate injectors. Replace the factory fitted injectors with the appropriate injectors, as supplied. Refer to injector orifice table for injector sizes. The injector size is stamped on the side of the injector.
2. Unscrew the top hat nut from the regulator. The top hat nut and control pressure spring assembly will disengage as an assembly.
3. Unscrew the threaded pin from top hat.
4. Upturn threaded pin, so spring is free and screw pin back into the top hat until firm.
5. Refit the top hat nut assembly to the regulator ensuring that it is fully screwed down. The regulator is now set for connection to LPG.
6. Turn on the gas supply and at each new connection check for leaks using soapy water. Each hotplate valve should be turned on, one at a time, and the injector hole blanked off for several seconds.
7. The operation of the regulator can be confirmed by connecting a manometer to the pressure test point located on the side of the regulator body adjacent to the outlet.

With the appliance operating check the outlet pressure:

- When all burners of the appliance are operating at maximum,
- When the smallest burner of the appliance is operating at minimum.

Under these conditions the outlet pressure should not vary from the nominal outlet pressure of 2.60kPa by more than $\pm 0.52\text{kPa}$.

8. If the regulator appears to not be performing satisfactorily then check the following points:
 - If the outlet pressure is consistently too low then the inlet pressure may be too low and adjustment of an upstream regulator may be needed, or an upstream regulator or valve with insufficient flow capacity may be present in the gas supply line. If this is suspected then it may be necessary to repeat the checks whilst measuring both the inlet and outlet pressure to determine if the inlet pressure is in the range 2.75 – 7.00kPa.
 - Check that the insert has been fitted correctly.
 - Check that the turret screw is fully screwed down.
 - Check that the regulator has been fitted to the gas supply line in the correct orientation, the arrow on the base of the body indicates the direction of gas flow.

Once these checks have been completed, if the regulator still fails to perform in a satisfactory manner it should be replaced.

9. One by one, turn the knobs to minimum and screw in the bypass screw (accessible when the knob is removed) until a small stable flame results. Turn the knob to maximum and then back to minimum to ensure that the correct minimum flame is maintained.
10. Attach the LPG sticker to the cooker, near the gas supply inlet. Cover the Natural Gas label that is factory fitted.

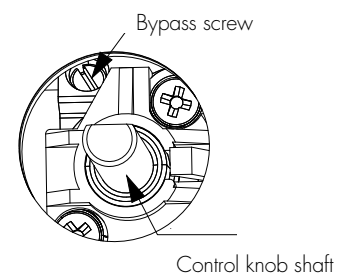
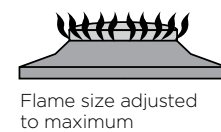
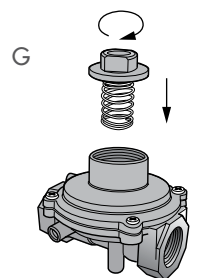
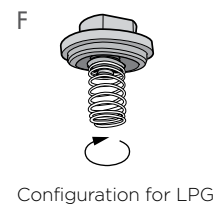
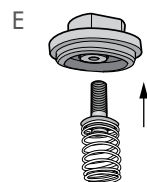
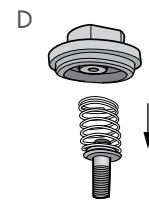
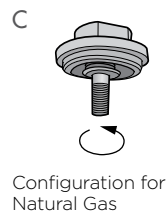
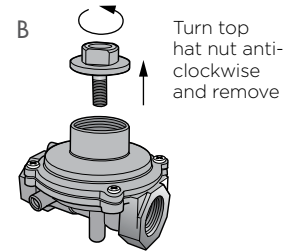
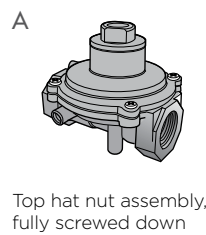

TESTING THE OPERATION OF THE GAS COOKER

NOTE: You MUST test the cooker after installation, before you hand it over to the customer.

You MUST have a manometer and a connecting tube.

Checking gas supply

1. Check the manometer zero point is correct.
2. Connect the manometer to the cooker pressure test point. This is located on the regulator or LPG inlet fitting.
3. Turn on the gas supply and the electricity and try to ignite the gas.

NOTE: It will take additional time to light the gas for the first time as air needs to be purged from the pipes.

4. Check the operating pressure for the particular gas type.

NOTE: For LPG cookers: Adjust the regulator if necessary (this may be remote from the cooker).

For Natural Gas cookers

Regulators are supplied pre-adjusted and configured by the component maker for use with Natural Gas. The appliance installer is not required to make an adjustment to obtain the correct outlet pressure setting.

An arrow on the base of the regulator indicates the direction of gas flow when the inlet and outlet of the regulator are orientated correctly. When the regulator has been fitted check for leaks from the connections with soapy water.

Checking the Function of the Regulator

With the appliance operating check the outlet pressure:

- When all burners of the appliance are operating at maximum,
- When the smallest burner of the appliance is operating at minimum.

Under these conditions the outlet pressure should not vary from the nominal outlet pressure by more than $\pm 20\%$ of the nominal outlet pressure (ie $\pm 0.20\text{kPa}$ for Natural Gas).

If the regulator appears to not be performing satisfactorily then check the following points.

1. If the outlet pressure is consistently too low then the inlet pressure may be too low and adjustment of an upstream regulator may be needed, or an upstream regulator or valve with insufficient flow capacity may be present in the gas supply line. If this is suspected then it may be necessary to repeat the checks whilst measuring both the inlet and outlet pressure to determine if the inlet pressure is in the range 1.13 – 5kPa.

2. Check that the regulator has been fitted to the gas supply line in the correct orientation, the arrow on the base of the body indicates the direction of gas flow.

Once these checks have been completed, if the regulator still fails to perform in a satisfactory manner it should be replaced.

Testing the cooker features

- Observe the flame appearance on each burner. If it is much smaller or larger than expected, then the injector size needs checking.

NOTE: When flame is unsatisfactory, then refer to the Electrolux Technical Publications and correct the fault, if possible.

When maximum flame appearance is correct, then check the turn-down setting on each burner. If the settings appear to be incorrect, proceed as follows:

1. Adjust the bypass screw mounted on the body of each hotplate control cock. This is accessible when the control knob is removed.
2. Check the ignition on all burners both separately and in combination.
3. Check the operation of the electrical components, if applicable.
4. If you are satisfied that the cooker is operating correctly, then turn it off and show the customer how to use it. Make sure you ask the customer to operate the controls.

NOTE: If the cooker cannot be adjusted to perform correctly, then inform the customer of the problem and put a warning notice on the cooker. If the problem is dangerous, then disconnect the cooker. If there is a fault, then the customer should be advised to contact the manufacturer's local service organisation or the retailer.

This document sets out the terms and conditions of the product warranties for Westinghouse Appliances. It is an important document. Please keep it with your proof of purchase documents in a safe place for future reference should there be a manufacturing defect in your Appliance. This warranty is in addition to other rights you may have under the Australian Consumer Law.

1. In this warranty:

- (a) 'ACL' or 'Australian Consumer Law' means Schedule 2 to the Competition and Consumer Act 2010;
- (b) 'Appliance' means any Electrolux product purchased by you and accompanied by this document;
- (c) 'ASC' means Electrolux's authorised serviced centres;
- (d) 'Westinghouse' is the brand controlled by Electrolux Home Products Pty Ltd of 163 O'Riordan Street, Mascot NSW 2020, ABN 51 004 762 341 in respect of Appliances purchased in Australia and Electrolux (NZ) Limited (collectively "Electrolux") of 3-5 Niall Burgess Road, Mount Wellington, in respect of Appliances purchased in New Zealand;
- (e) 'Warranty Period' means the period specified in clause 3 of this warranty;
- (f) 'you' means the purchaser of the Appliance not having purchased the Appliance for re-sale, and 'your' has a corresponding meaning.

2. Application: This warranty only applies to new Appliances, purchased and used in Australia or New Zealand and is in addition to (and does not exclude, restrict, or modify in any way) other rights and remedies under a law to which the Appliances or services relate, including any non-excludable statutory guarantees in Australia and New Zealand.

3. Warranty Period: Subject to these terms and conditions, this warranty continues in Australia for a period of 24 months and in New Zealand for a period of 24 months, following the date of original purchase of the Appliance.

4. Repair or replace warranty: During the Warranty Period, Electrolux or its ASC will, at no extra charge if your Appliance is readily accessible for service, without special equipment and subject to these terms and conditions, repair or replace any parts which it considers to be defective. Electrolux may, in its absolute discretion, choose whether the remedy offered for a valid warranty claim is repair or replacement. Electrolux or its ASC may use refurbished parts to repair your Appliance. You agree that any replaced Appliances or parts become the property of Electrolux.

5. Travel and transportation costs: Subject to clause 7, Electrolux will bear the reasonable cost of transportation, travel and delivery of the Appliance to and from Electrolux or its ASC. Travel and transportation will be arranged by Electrolux as part of any valid warranty claim.

6. Proof of purchase is required before you can make a claim under this warranty.

7. Exclusions: You may not make a claim under this warranty unless the defect claimed is due to faulty or defective parts or workmanship. This warranty does not cover:

- (a) light globes, batteries, filters or similar perishable parts;
- (b) parts and Appliances not supplied by Electrolux;
- (c) cosmetic damage which does not affect the operation of the Appliance;

- (d) damage to the Appliance caused by:
 - (i) negligence or accident;
 - (ii) misuse or abuse, including failure to properly maintain or service;
 - (iii) improper, negligent or faulty servicing or repair works done by anyone other than an Electrolux authorised repairer or ASC;
 - (iv) normal wear and tear;
 - (v) power surges, electrical storm damage or incorrect power supply;
 - (vi) incomplete or improper installation;
 - (vii) incorrect, improper or inappropriate operation;
 - (viii) insect or vermin infestation;
 - (ix) failure to comply with any additional instructions supplied with the Appliance;

In addition, Electrolux is not liable under this warranty if:

- (a) the Appliance has been, or Electrolux reasonably believes that the Appliance has been, used for purposes other than those for which the Appliance was intended, including where the Appliance has been used for any non-domestic purpose;
- (b) the Appliance is modified without authority from Electrolux in writing;
- (c) the Appliance's serial number or warranty seal has been removed or defaced

8. How to claim under this warranty: To enquire about claiming under this warranty, please follow these steps:

- (a) carefully check the operating instructions, user manual and the terms of this warranty;
- (b) have the model and serial number of the Appliance available;
- (c) have the proof of purchase (e.g. an invoice) available;
- (d) telephone the numbers shown below.

9. Australia: For Appliances and services provided by Electrolux in Australia: Electrolux goods come with guarantees that cannot be excluded under the Australian Consumer Law. You are entitled to a replacement or refund for a major failure and for compensation for any other reasonably foreseeable loss or damage. You are also entitled to have the Appliance repaired or replaced if the Appliance fails to be of acceptable quality and the failure does not amount to a major failure. 'Acceptable quality' and 'major failure' have the same meaning as referred to in the ACL.

10. New Zealand: For Appliances and services provided by Electrolux in New Zealand, the Appliances come with a guarantee by Electrolux pursuant to the provisions of the Consumer Guarantees Act, the Sale of Goods Act and the Fair Trading Act. Where the Appliance was purchased in New Zealand for commercial purposes the Consumer Guarantee Act does not apply.

11. Confidentiality: You accept that if you make a warranty claim, Electrolux and its agents including ASC may exchange information in relation to you to enable Electrolux to meet its obligations under this warranty.

Important Notice

Before calling for service, please ensure that the steps listed in clause 8 above have been followed.

<p>FOR SERVICE or to find the address of your nearest authorised service centre in Australia PLEASE CALL 13 13 49 <small>For the cost of a local call (Australia only)</small></p>	<p>AUSTRALIA ELECTROLUX HOME PRODUCTS 163 O'Riordan Street, Mascot NSW 2020 electrolux.com.au</p>	<p>FOR SPARE PARTS or to find the address of your nearest spare parts centre in Australia PLEASE 13 13 50 <small>For the cost of a local call (Australia only)</small></p>
<p>FOR SERVICE or to find the address of your nearest authorised service centre in New Zealand PLEASE CALL 0800 10 66 10 <small>(New Zealand only)</small></p>	<p>NEW ZEALAND ELECTROLUX (NZ) Limited 3-5 Niall Burgess Road, Mount Wellington electrolux.co.nz</p>	<p>FOR SPARE PARTS or to find the address of your nearest spare parts centre in New Zealand PLEASE 0800 10 66 20 <small>(New Zealand only)</small></p>

For more information on all Westinghouse appliances, or for dimension and installation information, call into your retailer, phone or email our customer care team or visit our website:

AUSTRALIA

phone: 1300 363 640

fax: 1800 350 067

email: customercare@electrolux.com.au

web: westinghouse.com.au

NEW ZEALAND

phone: 0800 436 245

fax: 0800 225 088

email: customercare@electrolux.co.nz

web: westinghouse.co.nz

TOP SERVICE

Top Service encompasses the after sales service provided by The Electrolux Group to consumers including delivery, home service and spare parts.

 and WESTINGHOUSE are trademarks of Westinghouse Electric Corporation. Used under license. All Rights Reserved.

P/No: 0342 001 625 Rev C ECN No. 109613
© 2019 Electrolux Home Products Pty Ltd.
ABN 51 004 762 341
WMAN_540_600_SU_Cooker_Mar19