

Dear Customer,

Thank you for purchasing an Electrolux oven. You've chosen a product that brings with it decades of professional experience and innovation. Intuitive and seamless, it has been designed with you in mind. We want to give you the tools to make great tasting food and to enrich your home life.

Welcome to Electrolux.

## ► Ready

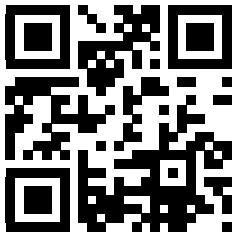

**This is a Quick Start Guide. Please refer to user manual online for detailed information and installation.**

To access your detailed user manual online, simply scan the QR code on your smart phone.

For more detailed information and installations guide refer to user manuals at [electrolux.com.au/support/manuals/](http://electrolux.com.au/support/manuals/)

### Before you start, please make sure:

- Your oven has been correctly installed by a qualified person.
- Your oven has power and is switched on.
- You've removed all relevant packaging.



Most of the packaging materials can be recycled. Please dispose of them at your local recycling centre or in your own recycling bin.

## ► Set Now let's get your oven ready to use:

### Get to know your oven control panel:

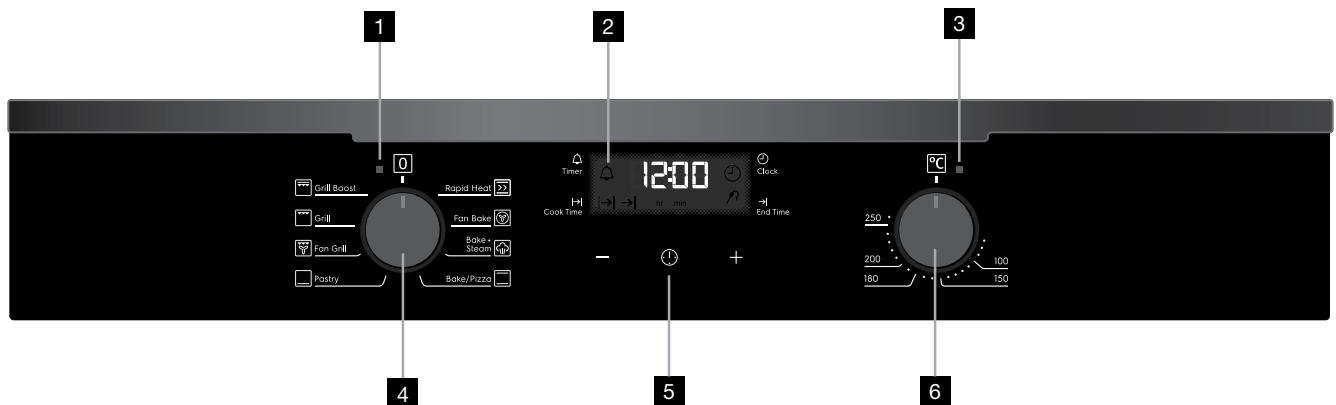

**1** Oven 'ON' light

**2** Timer display

**3** Heating light

**4** Function selector knob

**5** Touchpad

**6** Temperature selector knob

# ► Set!

## Installing the oven accessories

1. Install telescopic slides to the side racks (EVE614 only). Refer to installation guide supplied with oven slides.
2. Insert side racks
  1. Insert the rear peg into the rear access hole, ensuring peg is fully inserted.
  2. Then insert the front peg into the front access hole and push in firmly.

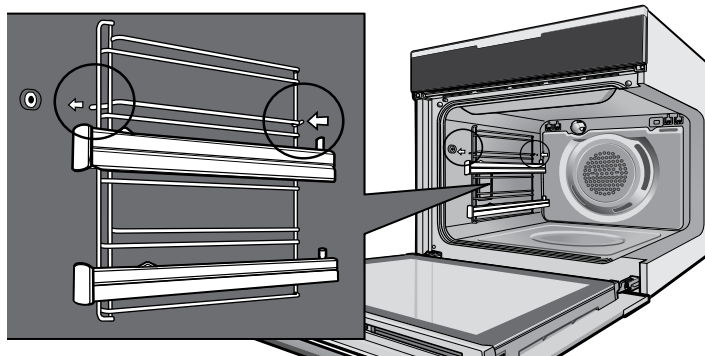

### 3. To fit a shelf:

1. Locate the detents on the side wires of the shelf, these should be towards the oven back wall. See image below.
2. Align the shelf to the same rail positions on both sides and slide the shelf in between the guide rails.
3. When fully inserted the shelf should not interfere with the closed oven door.

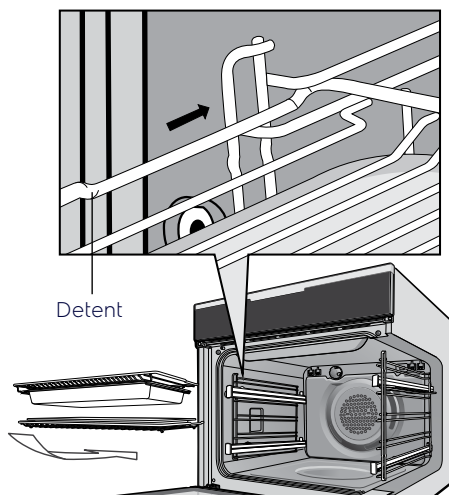

### 4. Fit shelf to telescopic slides (EVE614 only)

1. Push the shelf along the top of the slide until it hits the back post.

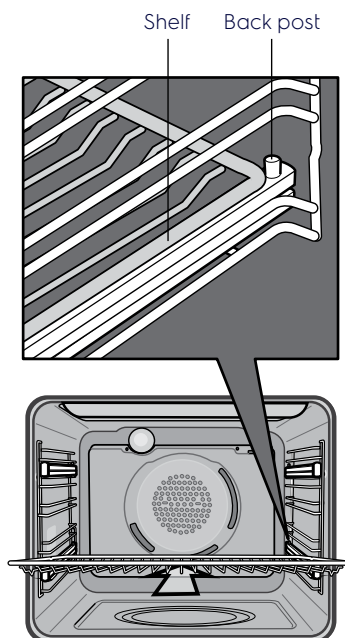

2. Drop the front of the shelf onto the slide ensuring it sits behind the front post of the slide.

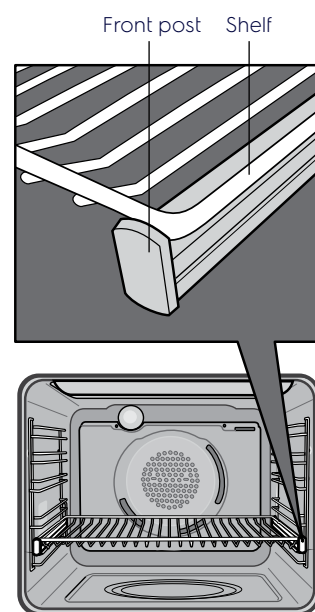

3. When fully inserted the shelf should not interfere with the closed oven door.

## Set the time

You must set the time before you can operate your oven.

1. After the appliance has been electrically connected, '12:00' will be displayed and the clock icon ⌚ will flash.
2. Use the timer + and - to set the time.
3. 5 seconds after the last change, the clock icon will disappear, confirming the time has been adjusted.

NOTE: The clock has a 24 hour display

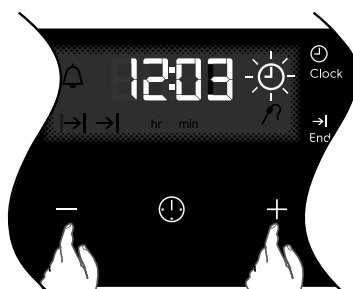

## Condition the oven

(to burn off any residue)

New appliances can have oil or residue left from manufacturing. You will need to heat your oven for 30 minutes before using it for the first time.

1. Turn the function selector knob to FAN BAKE.
2. Using the temperature selector, set the oven to 180°C and heat for approximately 30 minutes. Make sure your room is well ventilated during this time.

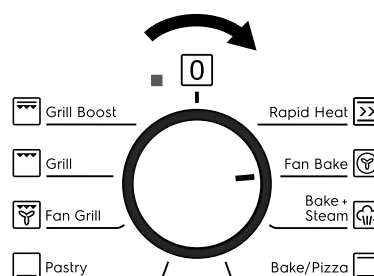

## ► Go! You're ready to use your new Electrolux appliance. A few tips from us:

### Remember to pre-heat each time

For best cooking results pre-heat the oven. Pre-heating allows the oven to reach the required temperature quickly and efficiently as well as cook food at the correct temperature for the entire cook time. Recommended pre-heat time is 30 mins for baking and 3 minutes for grilling.

### Choose the right program for the best result

#### Rapid Heat



Cooking frozen pre-cooked foods such as savoury pastries, pizzas, frozen dinners, meat pies and fruit pies

#### Fan Bake



Cooking on multiple shelves at once, reheating foods and complete meals.

#### Bake +Steam



Adding steam to your baking program can lift your baking skills to a whole new level. The Bake +Steam function uses a touch of steam to create a richer and glossier colour, a crispier crust and soft delicious texture for your home-baked goods.

#### Bake/Pizza



Baking a single tray of biscuits, scones, muffins, cakes, slices, casseroles, baked puddings, roasts and delicate egg dishes.

#### Fan Grill



Large cuts of meat, which gives you a result that is similar to 'rotisserie' cooked meat. When using 'Fan Grill' it is not necessary to turn food over during the cooking cycle. Set temperature to 180°C. **Fan grill with the oven door closed.**

#### Grill Boost



Tender cuts of meat, steak, chops, sausages, fish, cheese toasties and other quick cooking foods. For best results preheat your grill for 3 minutes to help seal in the natural juices for a better flavour. **Grill with the oven door closed.**

Refer to your full user manual for other oven functions.

### Set your temperature

1. To set the temperature, turn the temperature selector in a clockwise direction to the desired setting.
2. An indicator light in the display will turn on and the oven will begin to heat.
3. Once the food is cooked, turn the temperature selector back in an anti-clockwise direction.

The desired cooking function must be selected before the oven will turn on.

# Register your appliance

Easily register your product with your smartphone for quick access to all services and downloads

## Step 1

Locate the label on the inside of your product door

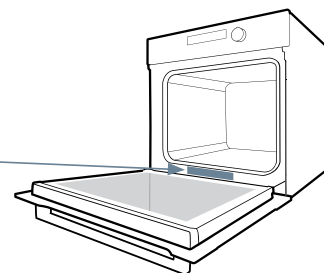
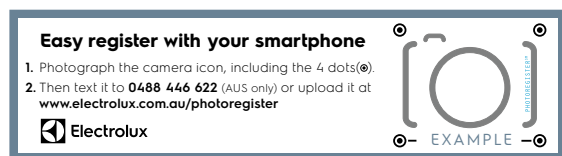

## Step 2

Photograph the camera icon, including the 4 dots (⦿)



## Step 3

Text image to **0488 446 622** (AUS only) or upload at **electrolux.com.au/photoregister**

# Need more help?

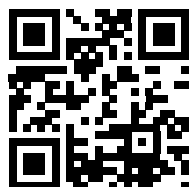

To access your detailed user manual online, simply scan the QR code on your smart phone.

# Contact us if you need more help

## Electrolux Home Products Australia

telephone: 13 13 49  
fax: 1800 350 067  
email: [customercare@electrolux.com.au](mailto:customercare@electrolux.com.au)  
web: [electrolux.com.au](http://electrolux.com.au)

## Electrolux Home Products New Zealand

telephone: 0800 436 245  
fax: 0800 225 088  
email: [customercare@electrolux.co.nz](mailto:customercare@electrolux.co.nz)  
web: [electrolux.co.nz](http://electrolux.co.nz)