

**Enjoy peace of mind.
Register your appliance today.**

Stay updated on better living services, safety notices and shop for accessories.

- 1. Open the camera app on your smartphone and point at the QR code to scan**
Product Registration QR code is located on the front of your appliance or inside the door rim*.

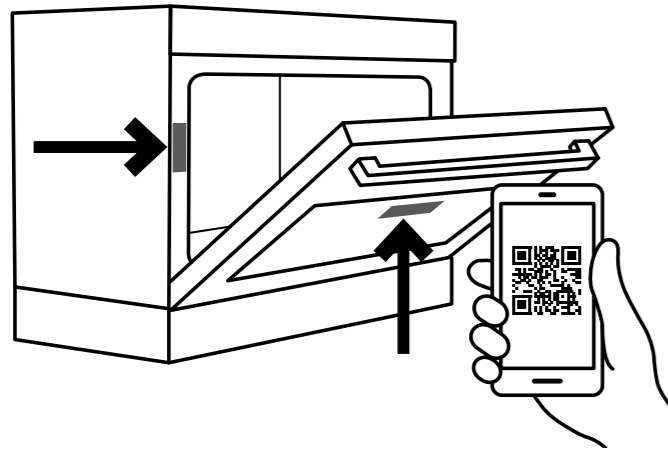

- 2. Tap the notification or link to open the registration form**
- 3. Complete your details and enjoy peace of mind**

*Exact location of QR code may vary depending on oven model



Need more help?

To access your detailed user manual online, simply scan the QR code on your smart phone. If you prefer a printed manual, please contact our Customer Care Centre using details below.



Customer Care Centre

Contact us if you need more help

Electrolux Home Products Australia

telephone: 13 13 49
email: customercare@electrolux.com.au
web: electrolux.com.au

Electrolux Home Products New Zealand

telephone: 0800 436 245
email: customercare@electrolux.co.nz
web: electrolux.co.nz

Dear Customer,

Thank you for purchasing a Westinghouse appliance. You have chosen a product that comes from a history of durable and reliable products loved by many families. We look to help you make the most of your time at home, so you can spend your time doing what you really love, with the ones you love.

Welcome to Westinghouse.

Ready



This is a Quick Start Guide. Please refer to user manual online for detailed information and installation

To access your detailed user manual online, simply scan the QR code on your smart phone.

For more detailed information and installation guide refer to user manuals at westinghouse.com.au/manuals

Before you start, please make sure:

- Your cooker has been correctly installed by a qualified person.
- Your cooker has power and is switched on.
- You've removed all relevant packaging.

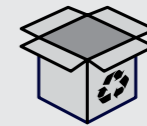

Most of the packaging materials can be recycled. Please dispose of them at your local recycling centre or in your own recycling bin.

Set...

Get to know your control panel:

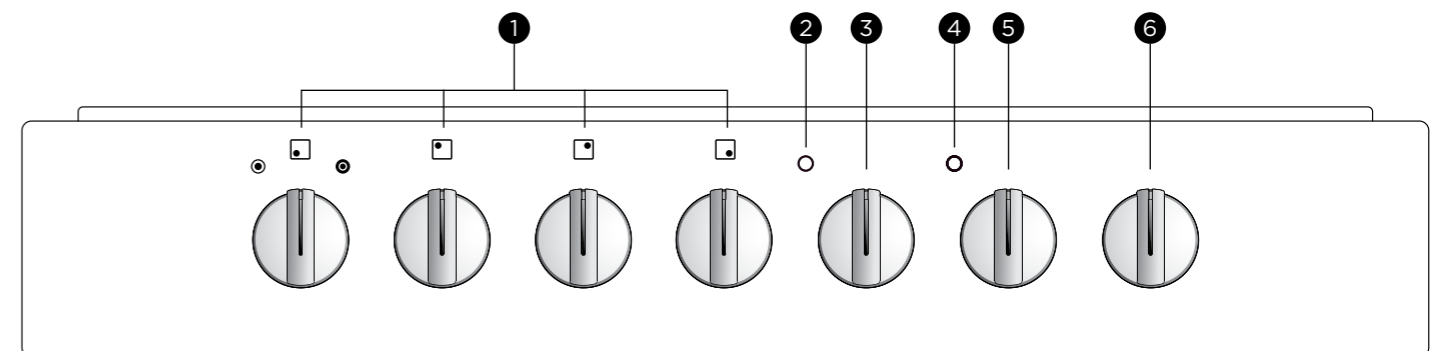

- | | | |
|--|---|------------------------------------|
| 1 Cooktop controls | 3 Grill temperature selector for WFE642, WFE542 models. Function selector for WFE646 model | 4 Oven indicator light |
| 2 Grill indicator light for WFE642, WFE542 models | | 5 Oven temperature selector |
| | | 6 Timer |

Set...

Installing the oven accessories

Fitting the oven shelves

1. Ensure shelf orientation is correct (refer to diagram below).
2. Slide oven shelves onto oven supports (side runners) at an angle until raised back of shelf is past the stop on oven supports (side runners).
3. Lower front of shelf and push in until stop is reached.
4. To remove oven shelves, withdraw to the stop and raise the front of shelf to clear the stop.

Oven shelf location

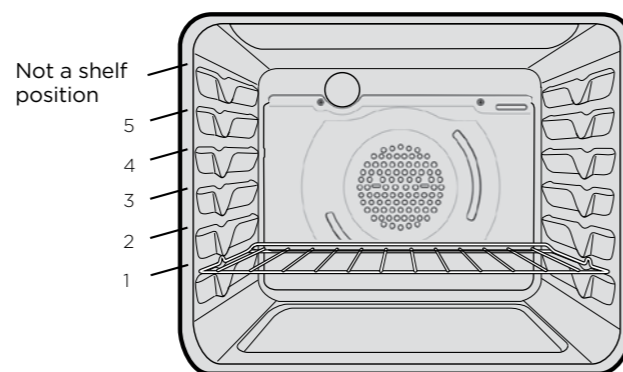

NOTE: The top ledge is not a shelf position. There are no stops for shelf withdrawal.

For separate grill models

To insert the grill tray in a separate grill underbench product, open the grill door and fully extend the grill drawer. Position the grill tray so that the slots on the outer edges fit over the tabs on the slides.

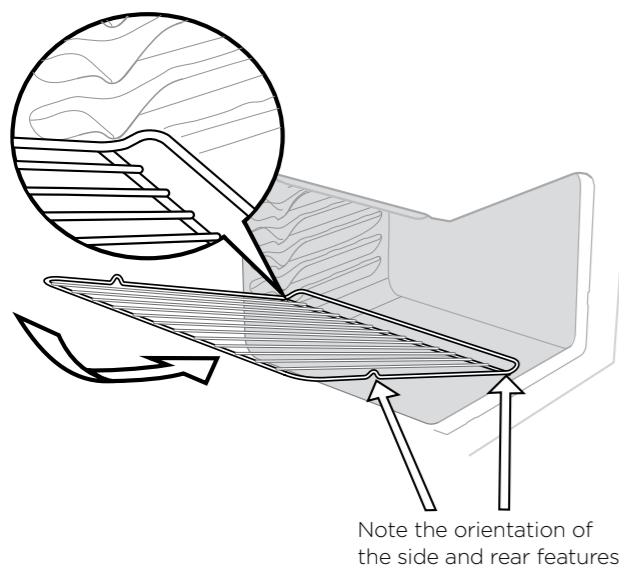
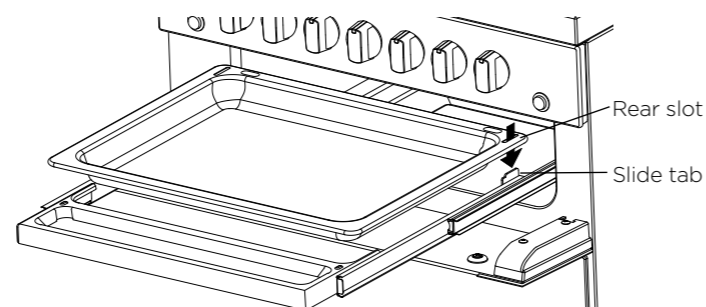

Note the orientation of the side and rear features

Condition the oven

(to burn off any residue)

New appliances can have oil or residue left from manufacturing. You will need to heat your oven for 30 minutes before using it for the first time.

1. For WFE646 model turn the function selector dial to "Fan Bake".
2. Using the oven temperature selector, set the oven at 180°C for approximately 30 minutes.
3. For separate grill models run grill on high for 15 minutes with the grill door open. Please ensure that the room is well ventilated during this process.

WFE646

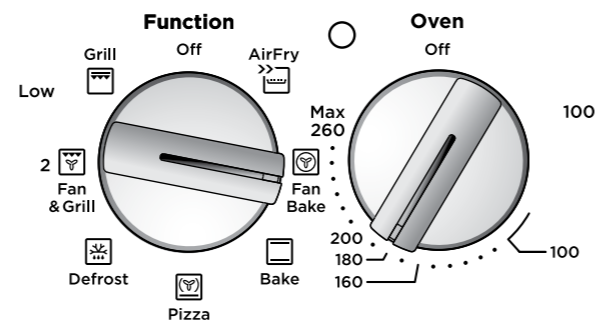

WFE542
WFE642

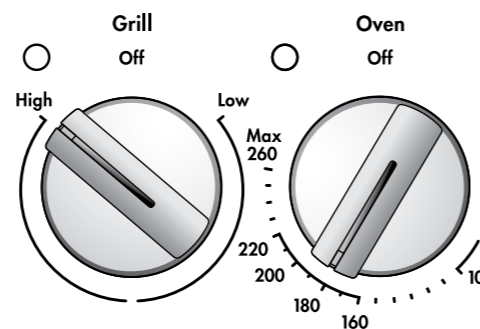

Go!

You're ready to use your new Westinghouse appliance. A few tips from us:

- Remember to pre-heat each time.

For best cooking results pre-heat the oven. Pre-heating allows the oven to reach the required temperature quickly and efficiently as well as cook food at the correct temperature for the entire cook time. Recommended pre-heat time is 30 minutes for baking and 3 minutes for grilling.

- Choose the right program for the best result:

CERAMIC
COOKTOP



Our range of ceramic cooktops combine stylish good looks with practical features to help you prepare delicious meals with ease and confidence. While the durable ceramic surface is tough enough to handle the everyday knocks of the busiest family kitchen, it must be remembered that the surface is made of glass and should not be treated as unbreakable.

OVEN



This setting is best used when cooking on multiple shelves at once or reheating complete meals for your family.

SEPARATE
GRILL

(For WFE642,
WFE542)



When it comes to cooking tender cuts of meat, steak, chops, sausages, fish, cheese toasties and other quick cooking foods the grill setting will get you the best results. By preheating your grill for 3 minutes this will help in sealing in the natural juices for a better flavour. Grill with the grill door open.

AIRFRY

(For WFE646
only)



AirFry enables advanced convection cooking function without having to turn the food, giving crispy great tasting results in a shorter time without all the oil. This is suitable for french fries, chicken wings, nuggets and similar products. A tray should be placed on the bottom shelf position, covered with foil, to catch any fat. Note: AirFry, bake and fan & grill functions are only available in WFE646 models.

BAKE



This setting is ideal for baking cookies, cakes and other bakery items. Both elements are controlled by the thermostat and turn on and off to maintain the set temperature, keeping your cakes cooking evenly.

FAN &
GRILL



When cooking large cuts of meat, this setting gives you result that is similar to 'roisserie' cooked meat. When using 'Fan Grill' it is not necessary to turn food over during the cooking cycle. Set temperature to 180°C and cook with the oven door closed.

Refer to your full user manual for more details on oven functions.

- Set your temperature

- To set the temperature, turn the oven temperature selector in a clockwise direction to the desired setting.
- An indicator light in the display will turn on and the grill/oven will begin to heat.
- Once the food is cooked, turn the oven temperature selector back in an anti-clockwise direction to the 'Off' position.

Note: For WFE646 models, the desired cooking function must be selected before the oven will turn on. The oven indicator light cycles on and off to maintain the required temperature in the oven.

- Set a Timer (where fitted)

- To set the timer, simply turn the knob clockwise to the required number of minutes.

NOTE: For any time below 10 minutes, turn the knob past the 30 minute mark, then turn it back to the required number of minutes.