

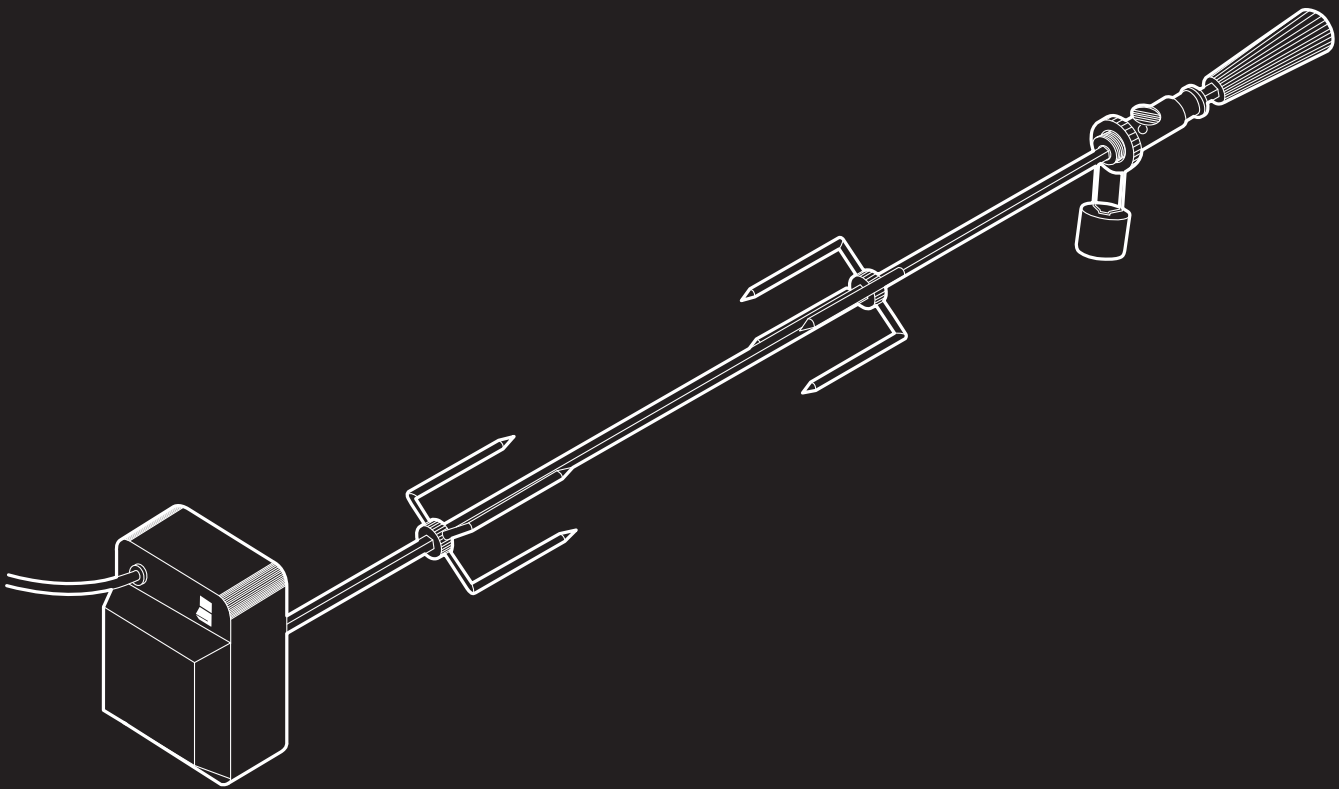

Assembly and Operating Instructions

ROTISSERIE

BR400, BR500



FOR OUTDOOR USE ONLY

AUSTRALIA / NEW ZEALAND

CONGRATULATIONS

Dear customer,

Congratulations and thank you for choosing our appliance. We are sure you will find it a pleasure to use. Before you use the appliance, we recommend that you read through the relevant sections of this manual, which provide a description of your appliance and its functions.

To avoid the risks that are always present when you use an appliance, it is important that the appliance is installed correctly and that you read the safety instructions carefully to avoid misuse and hazards.

We recommend that you keep this instruction booklet for future reference and pass it on to any future owners.

After unpacking the appliance, please check it is not damaged. If in doubt, do not use the appliance but contact your local customer care centre.

The symbols you will see in this booklet have these meanings:



WARNING

This symbol indicates information concerning your personal safety.



CAUTION

This symbol indicates information on how to avoid damaging the appliance.



IMPORTANT

This symbol indicates tips and information about use of the appliance.



ENVIRONMENT

This symbol indicates tips and information about economical and ecological use of the appliance.

IMPORTANT INFORMATION THAT MAY IMPACT YOUR MANUFACTURER'S WARRANTY

Adherence to the directions for use in this manual is extremely important for health and safety. Failure to strictly adhere to the requirements in this manual may result in personal injury, property damage and affect your ability to make a claim under the BeefEater manufacturer's warranty provided with your product. Products must be used, installed and operated in accordance with this manual. You may not be able to claim on the BeefEater manufacturer's warranty in the event that your product fault is due to failure to adhere this manual.



IMPORTANT

Important – check for any damages or marks

- If you find the appliance is damaged or marked, you must report it within 7 days if you wish to claim for damage/marks under the manufacturer's warranty. This does not affect your statutory rights.
- We recommend you do not exceed the maximum load of 6kg to ensure optimal performance and care for your product.
- It is recommended you do not use this product with the BBQ hood open. The rotisserie is designed for hood-down roasting.
- For best results, it is recommended you roast on lower heat over longer periods rather than intense heat in shorter bursts.



ENVIRONMENT

Information on disposal for users

- Most of the packing materials are recyclable. Please dispose of those materials through your local recycling depot or by placing them in appropriate collection containers.
- If you wish to discard this product, please contact your local authorities and ask for the correct method of disposal.



CAUTION – ELECTRICAL WARNING

If your barbecue incorporates an electrical component, such as a rotisserie, then it must be electrically grounded in accordance with local codes. The electric cord must be equipped with a three-pin (grounding) plug for your protection against shock hazard and should be plugged directly into a properly grounded three-pin receptacle. Do not cut or remove the grounding pin from this plug. Keep any electrical supply cord and the fuel supply hose away from any heated surfaces.

If an external electrical source is utilised, this outdoor cooking appliance, when installed, must be electrically grounded in accordance with the local codes or, in the absence of local codes with the following:

USA: National Electrical Code, ANSI/NFPA 70

CAN: Canadian Electrical Code, CSA C22.1

AUS: Aust Standards Code AS:5601

BEFORE YOU START



Before you start

Note the tools you will need before you begin.
Remove any protective plastic from stainless steel components.
Check for damaged or missing parts, and consult your retailer if necessary.











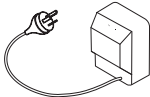

Adjustable spanner/wrench

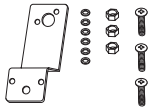
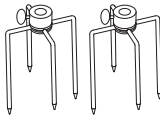

Phillips head screwdriver

Contents

Note: This rotisserie pack contains all of the below items (with the exception of item 'O'). Please refer carefully to the instructions below to identify which parts are relevant to you depending on what model BBQ you have. Please check your BBQ series and model before commencing.

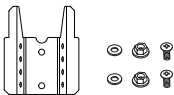
A		Rotisserie Shaft	1
B		Motor and plug	1
C		Bracket	1
D		Bracket	1
E		Counterweight	1
F		Weight	1
G		Set consists of: Bracket Washers Nuts Long Bolts	1 6 3 3
H		Prongs	2
I		Handle	1
J		Small Bracket	
K		Short Bolts	2
L		Nuts	2
M		Star Washers	2
N		Spacers	2
O		Set consists of: Bracket Bolts Washers Nuts	1 2 2 2

NOTE: This bracket is only applicable for 7000 series BBQ models and is not included in this pack. This is supplied with your BBQ.

CHECK PARTS

Check parts required for your bbq

Please refer to the table below to identify what parts and configuration you need to suit your BBQ. Please check your BBQ model number before commencing installation of rotisserie.

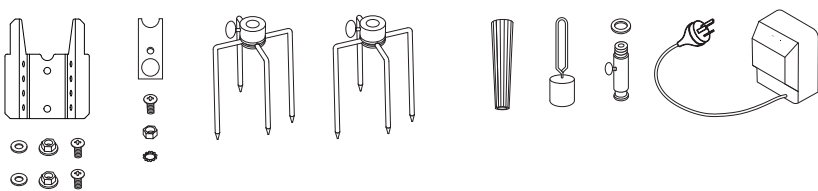
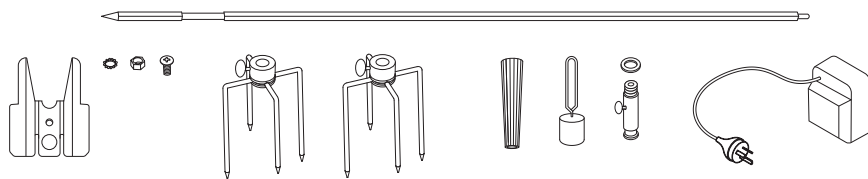
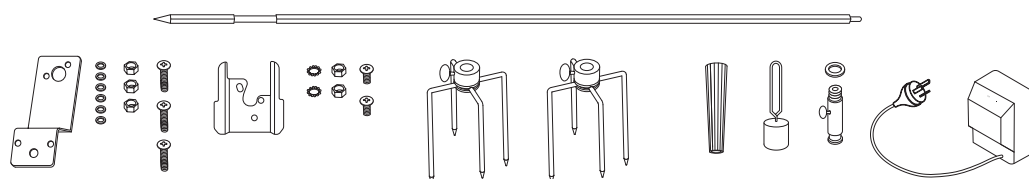
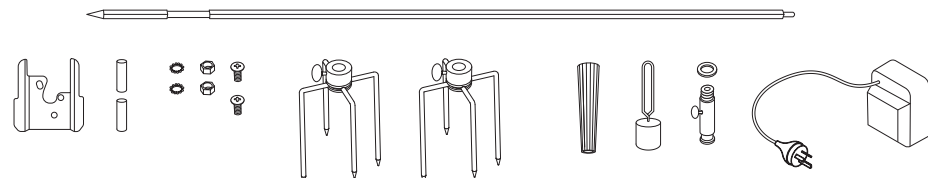
BBQ Series	Parts Required
7000	A, B, E, F, H, I, J, K, L, M, O 
1600 2000	A, B, C, E, F, G, H, I, K, L, M 
1200	A, B, D, E, F, G, H, I, K, L, M 
3000S 3000E 1100S 1000E	A, B, D, E, F, H, I, K, L, M, N 
1500	N/A - not compatible with this rotisserie
PROLINE	N/A - not compatible with this rotisserie

ASSEMBLY

Step 1

Remove the plastic end cap.

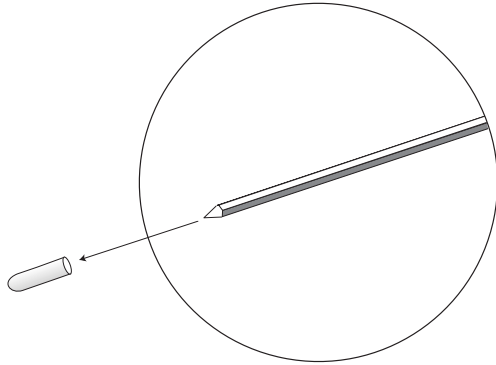

Step 2

Assemble the knurled nut, counterweight, collar and handle onto the threaded end of the shaft. Tighten the wing nut on the collar once all parts are in place.

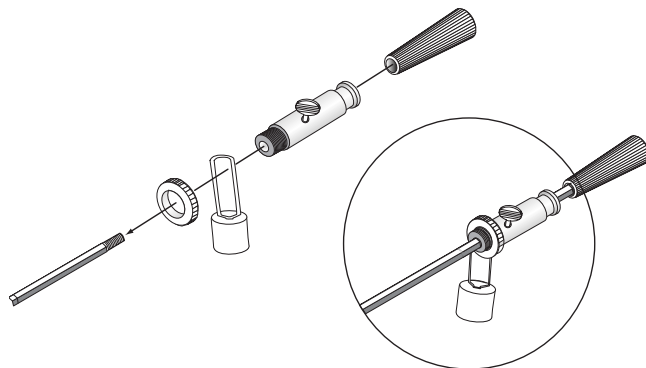

Step 3

Slide the prongs onto the shaft so they face each other.

Meat is secured between the prongs. Tighten the wing nuts on the prongs when the meat is in place.

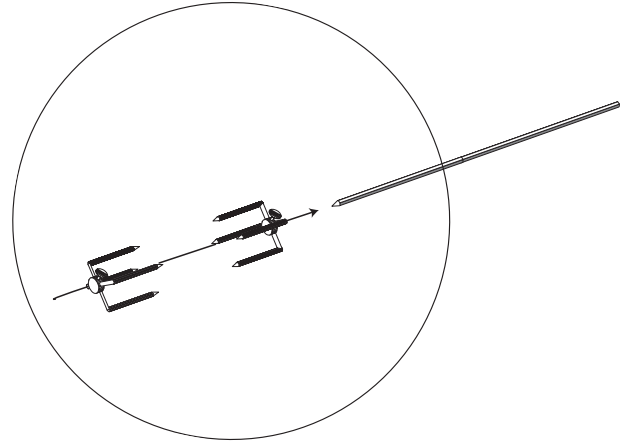

Step 4

Use the counterweight to balance the load, so that the shaft and meat rotate smoothly.

To balance the load, loosen the knurled nut, then allow the shaft to rotate freely and come to rest. This can be done holding the shaft in your hands. The heaviest part of the meat will naturally rotate to the bottom. Now rotate the counterweight so that the weight is toward the top.

If the meat is very lopsided, extend the counterweight so that it is furthest from the shaft. If the meat is close to being centrally balanced, shift the counterweight so that it is closer to the shaft.

Retighten the nut once a reasonable balance is achieved.

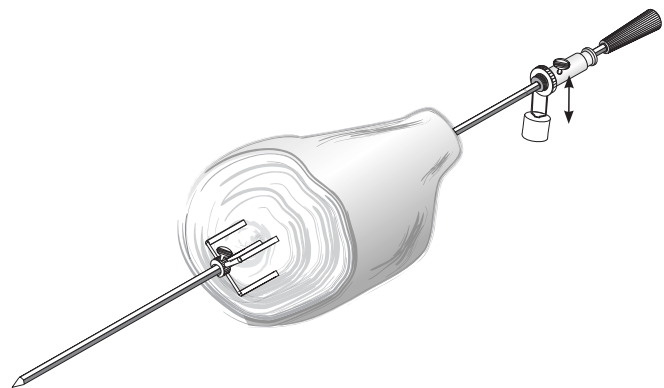

ATTACH TO BARBECUE - 7000 SERIES

Step 1

First, attach the motor mounting bracket (**O**) to the left side of the roasting hood.

Use the bracket which has two screw holes. The bracket is secured to the barbecue with two nuts, washers and screws.

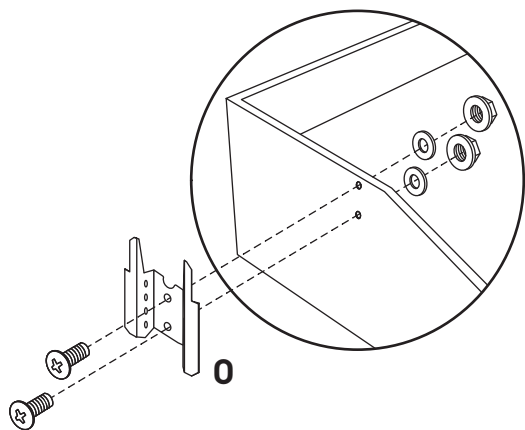

Step 2

Then slide the motor onto the bracket. Note the cable is towards the bottom.

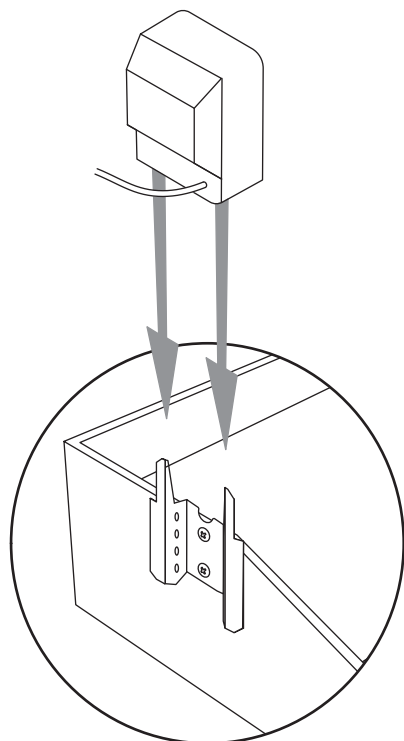

Step 3

Attach the small bracket (**J**) to the right side of the barbecue body. Similarly to the other side, use a single nut and screw.

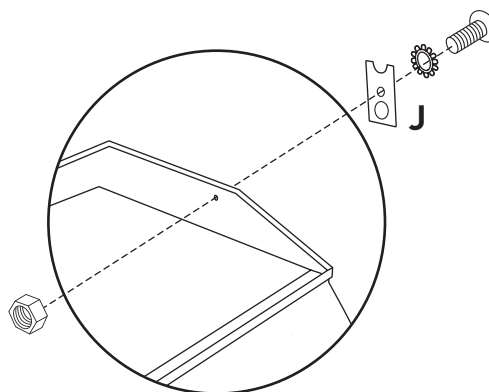

Step 4

Fit the shaft onto the roasting hood.

First insert the pointed end into the motor.

On the other end of the shaft, the groove of the collar rests directly onto the mounting bracket. You may need to loosen the wing nut on the collar to reposition it if necessary.

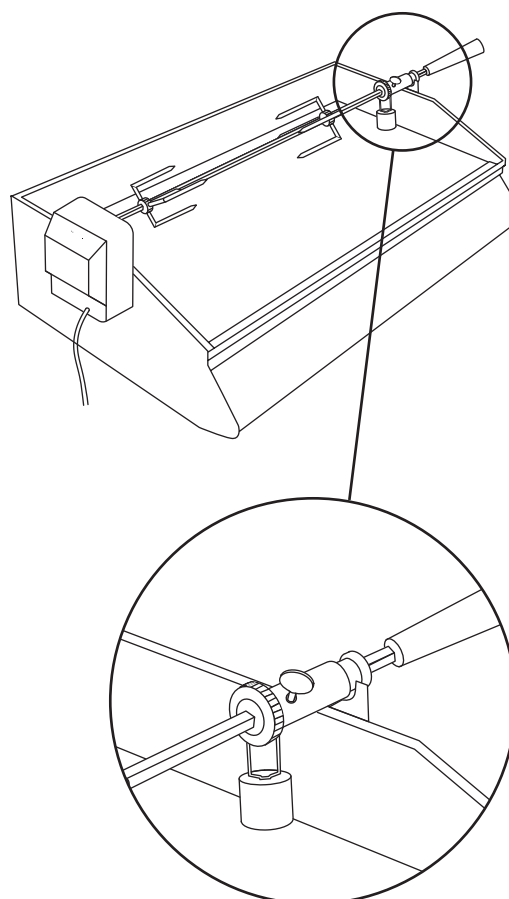

Step 1

First, attach the motor mounting bracket (C) to the left side of the roasting hood.

Use the bracket which has one screw hole only. The bracket is secured to the barbecue with a single nut and screw. The dome shaped bump in the bracket presses into the barbecue body and prevents the bracket from rotating.

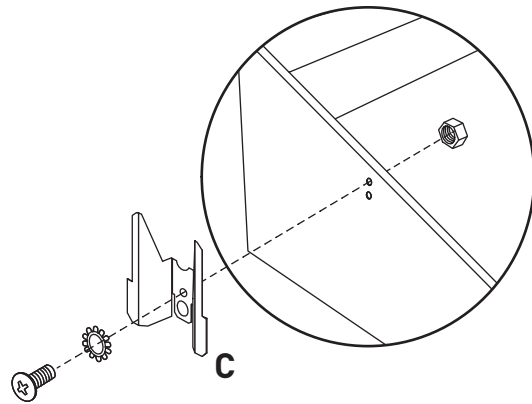

Step 3

Fit the shaft onto the roasting hood.

First insert the pointed end into the motor.

On the other end of the shaft, the groove of the collar rests directly onto the mounting bracket. You may need to loosen the wing nut on the collar to reposition it if necessary.

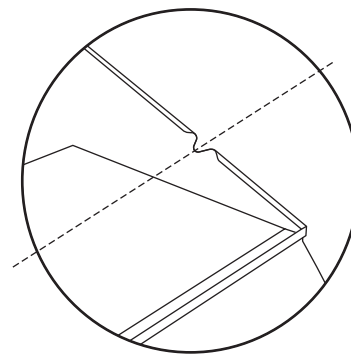

Step 2

Then slide the motor onto the bracket. Note the cable is towards the top.

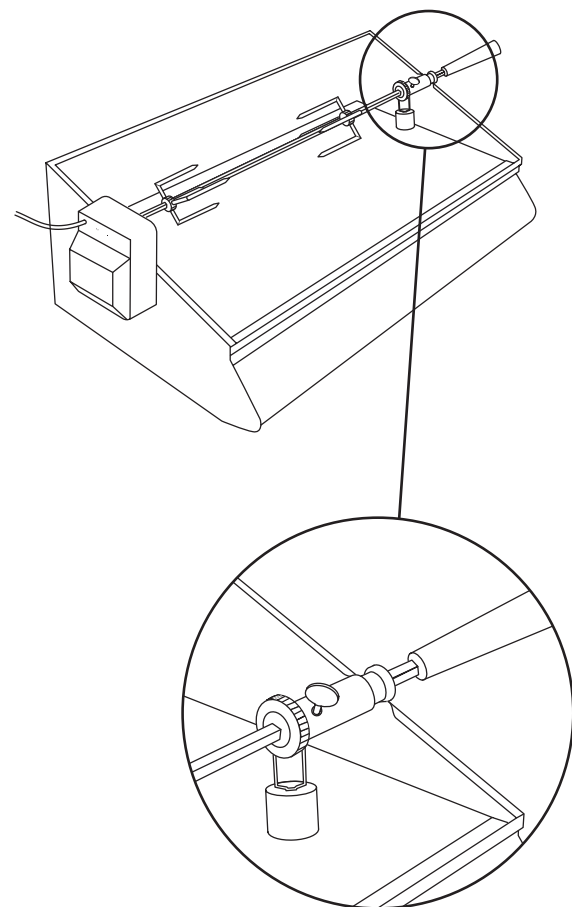
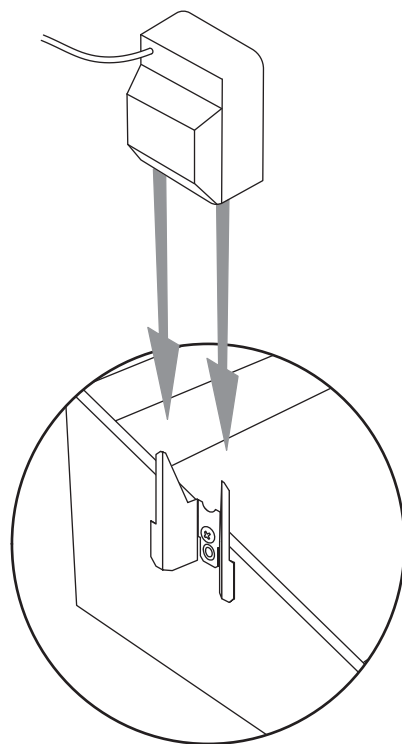

ATTACH TO BARBECUE - 1200 SERIES

Step 1

1. Attach the supporting bracket **(G)** to the left side of the roasting hood as shown in the below illustration.
Place the three-screw hole end of the supporting bracket in alignment with the existing three holes on the roasting hood.
The bracket is secured to the barbecue with three nuts, washers and screws.
2. Attach the motor mounting bracket **(D)** to the top section of the supporting bracket as shown in the below illustration.
Place the two diagonal screw holes in alignment with the existing diagonal screw holes on the supporting bracket **(G)**.
The motor mounting bracket is secured with two nuts, washers and screws.

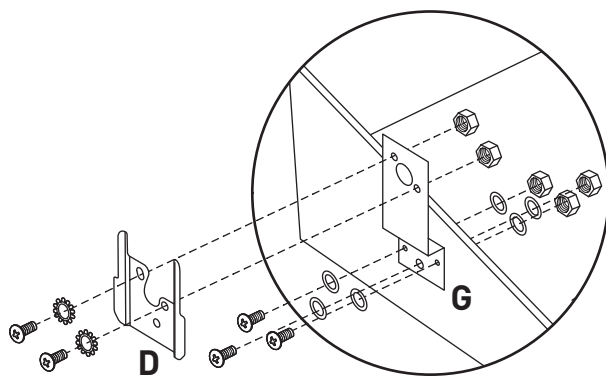

Step 2

Then slide the motor onto the bracket. Note the cable is towards the bottom.

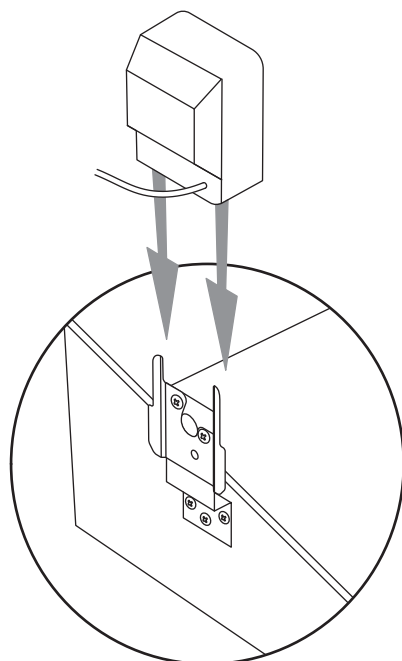

Step 3

- Fit the shaft onto the roasting hood.
First insert the pointed end into the motor.
On the other end of the shaft, the groove of the collar rests directly onto the mounting bracket. You may need to loosen the wing nut on the collar to reposition it if necessary.

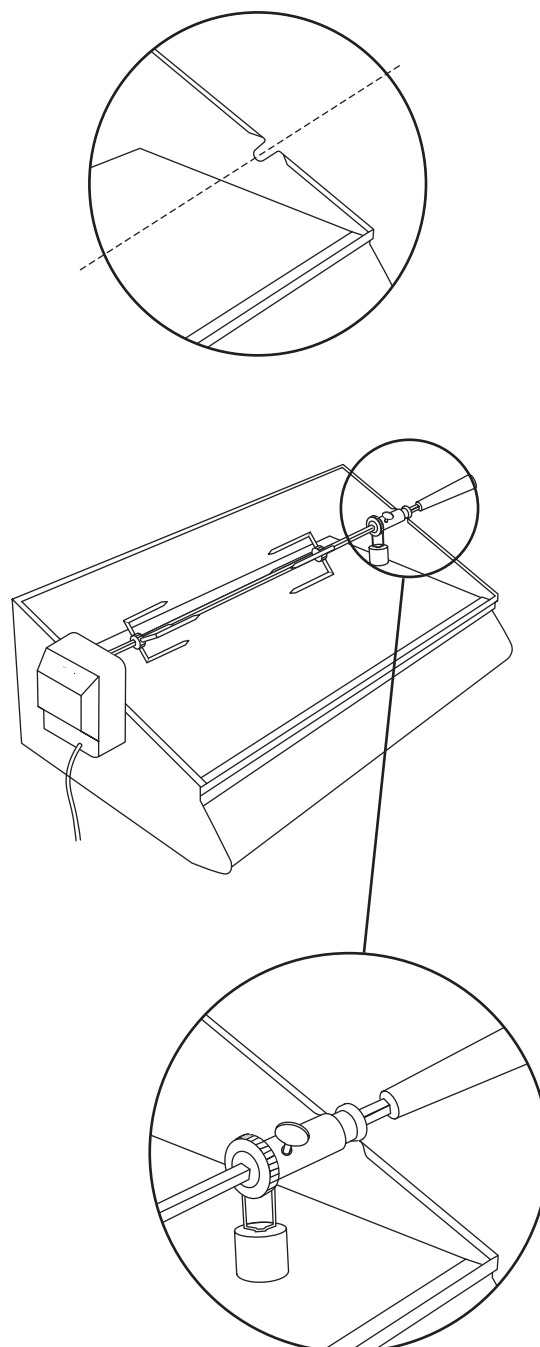

Step 1

Attach the motor mounting bracket **(D)** to the left side of the roasting hood.

Use the bracket which has two screws diagonally apart.

The cylindrical spacers are used to separate the bracket from the hood.

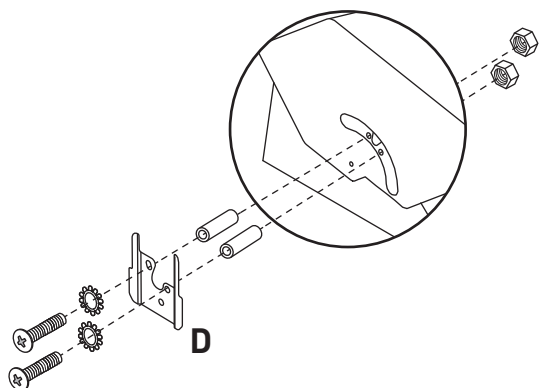

Step 2

Then slide the motor onto the bracket. Note the cable is towards the top.

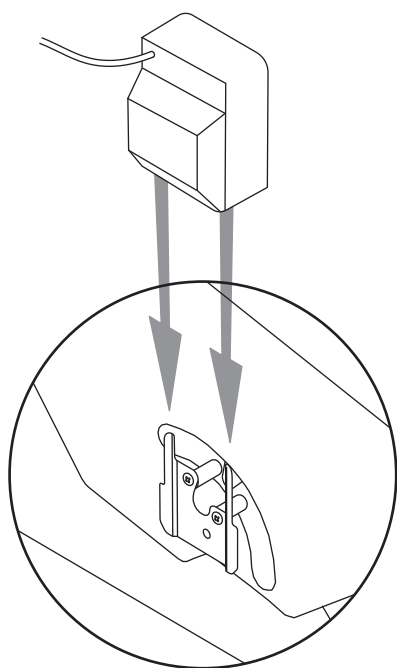

Step 3

Fit the shaft onto the roasting hood.

First insert the pointed end into the motor.

On the other end of the shaft, the groove of the collar rests directly onto the mounting bracket. You may need to loosen the wing nut on the collar to reposition it if necessary.

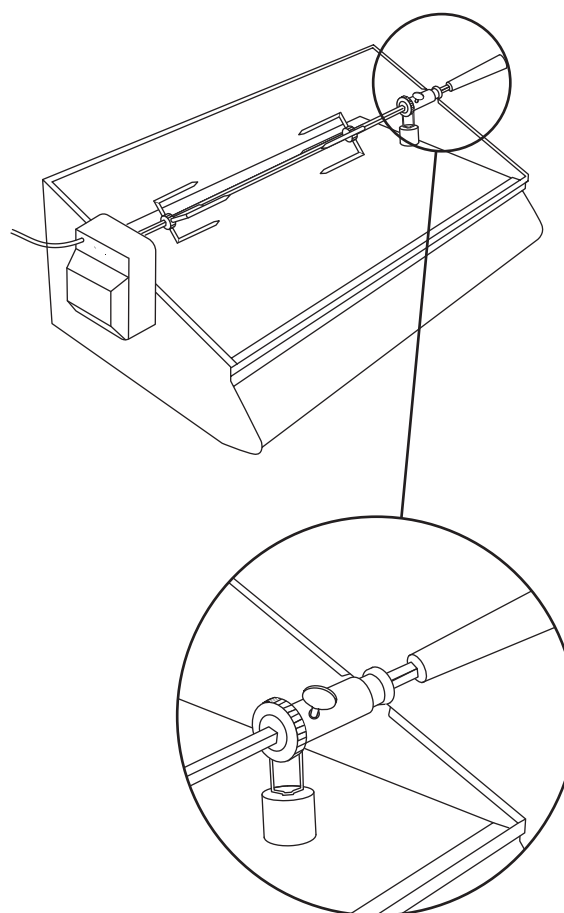
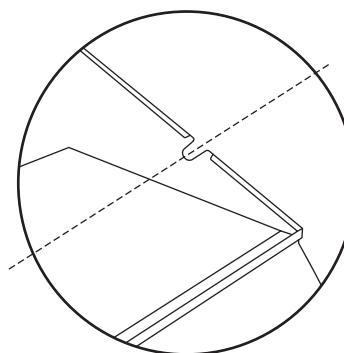

NOTES

Electrolux Warranty

FOR SALES IN AUSTRALIA AND NEW ZEALAND
APPLIANCE: ELECTROLUX SPARE PARTS & ACCESSORY PRODUCTS

This document sets out the terms and conditions of the product warranties for Electrolux Spare Parts and Accessory Products. It is an important document. Please keep it with your proof of purchase documents in a safe place for future reference should there be a manufacturing defect in your Product. This warranty is in addition to other rights you may have under the Australian Consumer Law.

1. In this warranty:

- (a) 'ACL' or 'Australian Consumer Law' means Schedule 2 to the Competition and Consumer Act 2010;
- (b) 'Product' means any Electrolux spare part and accessory product purchased by you and accompanied by this document;
- (c) 'ASPD' means Electrolux's Authorised Spare Parts Distributor;
- (d) 'Electrolux' is the brand controlled by Electrolux Home Products Pty Ltd of 163 O'Riordan Street, Mascot NSW 2020, ABN 51 004 762 341 in respect of Products purchased in Australia and Electrolux (NZ) Limited (collectively "Electrolux") of 3-5 Niall Burgess Road, Mount Wellington, in respect of Products purchased in New Zealand;
- (e) 'Warranty Period' means the period specified in clause 3 of this warranty;
- (f) 'you' means the purchaser of the Product not having purchased the Product for re-sale, and 'your' has a corresponding meaning.

2. Application: This warranty only applies to new Products, purchased and used in Australia or New Zealand and is in addition to (and does not exclude, restrict, or modify in any way) other rights and remedies under a law to which the Products or services relate, including any non-excludable statutory guarantees in Australia and New Zealand.

3. Warranty Period: Subject to these terms and conditions, this warranty continues for a period of 12 months in Australia and New Zealand, following the date of original purchase of the Product.

4. Repair or replace warranty: During the Warranty Period, Electrolux or its ASPD will, at no extra charge, subject to these terms and conditions, repair or replace any Product or parts which it considers to be defective. Electrolux may, in its absolute discretion, choose whether the remedy offered for a valid warranty claim is repair or replacement. Electrolux or its ASPD may use refurbished parts to repair your Product. You agree that any replaced Products or parts become the property of Electrolux.

5. Travel and transportation costs: Subject to clause 7, Electrolux will bear the reasonable cost of transportation, travel and delivery of the Product to and from Electrolux or its ASPD. Travel and transportation will be arranged by Electrolux as part of any valid warranty claim.

6. Proof of purchase is required before you can make a claim under this warranty.

7. Exclusions: You may not make a claim under this warranty unless the defect claimed is due to faulty or defective parts or workmanship. This warranty does not cover:

- (a) light globes, batteries, filters or similar perishable parts;
- (b) parts and Products not supplied by Electrolux;

- (c) cosmetic damage which does not affect the operation of the Product;
- (d) damage to the Product caused by:
 - (i) negligence or accident;
 - (ii) misuse or abuse, including failure to properly maintain or service;
 - (iii) improper, negligent or faulty servicing or repair works done by anyone other than an Electrolux authorised repairer or ASPD;
 - (iv) normal wear and tear;
 - (v) power surges, electrical storm damage or incorrect power supply;
 - (vi) incomplete or improper installation;
 - (vii) incorrect, improper or inappropriate operation;
 - (viii) insect or vermin infestation;
 - (ix) failure to comply with any additional instructions supplied with the Product;

In addition, Electrolux is not liable under this warranty if:

- (a) the Product has been, or Electrolux reasonably believes that the Product has been, used for purposes other than those for which the Product was intended, including where the Product has been used for any non-domestic purpose;
- (b) the Product is modified without authority from Electrolux in writing;
- (c) the Product's serial number or warranty seal has been removed or defaced.

8. How to claim under this warranty: To enquire about claiming under this warranty, please follow these steps:

- (a) carefully check the operating instructions, user manual and the terms of this warranty;
- (b) have the model and serial number of the Product available;
- (c) have the proof of purchase (e.g. an invoice) available;
- (d) contact us online or by phone at the details below.

9. Australia: For Products and services provided by Electrolux in Australia: Electrolux goods come with guarantees that cannot be excluded under the Australian Consumer Law. You are entitled to a replacement or refund for a major failure and for compensation for any other reasonably foreseeable loss or damage. You are also entitled to have the Product repaired or replaced if the Product fails to be of acceptable quality and the failure does not amount to a major failure. 'Acceptable quality' and 'major failure' have the same meaning as referred to in the ACL.

10. New Zealand: For Products and services provided by Electrolux in New Zealand, the Products come with a guarantee by Electrolux pursuant to the provisions of the Consumer Guarantees Act, the Sale of Goods Act and the Fair Trading Act. Where the Product was purchased in New Zealand for commercial purposes the Consumer Guarantee Act does not apply.

11. Confidentiality: You accept that if you make a warranty claim, Electrolux and its agents including ASPD may exchange information in relation to you to enable Electrolux to meet its obligations under this warranty.

Important Notice

Before calling for support, please ensure that the steps listed in clause 8 above have been followed.

 Need help, contact us	AUSTRALIA Electrolux Home Products Australia phone: 1300 307 939 email: customercare@beefeaterbbq.com web: beefeaterbbq.com	 SERVICE Simply scan the QR code on your smartphone to book online or find an authorised service centre  OR PHONE 1300 307 939 (Australia only)	 ACCESSORIES and SPARE PARTS Shop online at shop.beefeaterbbq.com.au for genuine accessories and spare parts  OR PHONE 13 13 50 (Australia only)
	NEW ZEALAND ELECTROLUX (NZ) Limited phone: 0800 436 245 email: customercare@electrolux.co.nz web: beefeaterbbq.com	 SERVICE PHONE 0800 10 66 10 (New Zealand only) to find your nearest authorised service centre	 ACCESSORIES and SPARE PARTS PHONE 0800 10 66 20 (New Zealand only) For genuine accessories and spare parts



Customer Care Centre

Contact us if you need more help

AUSTRALIA

phone: 1300 307 939

email: customercare@beefeaterbbq.com

web: beefeaterbbq.com

NEW ZEALAND

phone: 0800 436 245

email: customercare@electrolux.co.nz

web: beefeaterbbq.com